



## Advanced Diploma of **ELECTRICAL AND INSTRUMENTATION (E&I) ENGINEERING FOR MINING\*\***

### COMMENCEMENT DATE:

For upcoming commencement dates, please view our course schedule at:  
<http://www.eit.edu.au/schedule>

Remain at the cutting edge of electrical and electronic mining technology  
Participate from your home or office through live, interactive webinars  
Learn from world-renowned experts in mining technology  
Join the next generation of mining engineers

### WHAT YOU WILL GAIN:

- Skills and know-how in the latest electrical and instrumentation technologies used in mining operations all over the world
- Practical guidance from mining experts in the field
- 'Hands-on' knowledge from the extensive experience of the instructors, rather than from only the theoretical information gained from books and college reading
- Credibility as a mining expert in your firm
- Networking contacts in the industry
- Improved career prospects and income
- An EIT Advanced Diploma of Electrical and Instrumentation (E&I) Engineering for Mining

Visit our website:  
[www.eit.edu.au](http://www.eit.edu.au)

\*\*A note regarding recognition of this course in the Australian education system: The EIT is the owner of this course. The course is officially accredited within the Australian Qualifications Framework by the Training Accreditation Council, and is approved by the Australian Skills Quality Authority (ASQA) for delivery by the EIT in all Australian states. The EIT delivers this course to students worldwide.

## Introduction

Mining equipment has come a long way since the days of mule-drawn carriages for haulage, and canaries or Davy lamps for safety.

In terms of high-voltage equipment, large AC and DC motors are still at the order of the day, but with increased sophistication. Load-haul-dump trucks operate in hazardous environments without a driver on board. Sophisticated motor control centers now house variable speed drives and soft-starters, and the motor control equipment is often networked via Ethernet.

It is, however, on the low-voltage side where the developments are almost breathtaking. In certain parts of the world all mines in the region are monitored centrally on a SCADA system, with backhauls (fiber and wireless) to all mines in the region, forming a large Wide Area Network.

At the mine sites Ethernet networks, both wired and wireless, are at the order of the day both above and below ground level. Leaky Feeder wireless systems are still to be found, but nowadays they support Ethernet and TCP/IP, making them suitable for voice and data. IEEE802.11 wireless (a.k.a. Wi-Fi), suitably adapted for the mining environment, is making vast inroads into mining operations. Wi-Fi-based systems are used for both data and voice (VoIP), and with suitable radio frequency ID interfaces they also provide the infrastructure for monitoring personnel and vehicle movement. Some 802.11-based systems can even be configured in mesh topologies, delivering military-grade reliable communications between moving personnel and vehicles in an open mine environment.

Industrial field buses such as HART, AS-i, Profibus, Foundation Fieldbus and DeviceNet are widely used in the mining industry. As is the case with most other electronics, they are increasingly moving towards a co-existence with Ethernet, and augmentation with wireless. And, of course, some of them can perform safety functions as well as operate in intrinsically safe environments.

SCADA and distributed control is at the order of the day, and data from these systems are used as inputs to expert systems. These systems are used for various purposes such as providing data for optimized mine management, safety, and advanced process control. It is, in many cases, not even necessary for control room staff to understand anything about PID control in order to optimize a given control loop; the advanced process control system will heed their 'operator' inputs and optimize the process on their behalf.

Personal safety has not lagged behind. For example, ground radar can detect sub-millimeter ground movements, UWB and Wi-Fi systems are teamed up to avoid collisions between people and vehicles, and integrated headlamps for miners not only have built-in radio communications facilities, but also Ultra-Low Frequency ground-to-surface pagers for emergency location.

So, in short, the mining industry is attracting the best of the best cutting-edge commercial and industrial electrical and electronics technologies. The question is are you capable of dealing with it? Welcome to the EIT Advanced Diploma of Electrical and Instrumentation (E&I) Engineering for Mining.



*"If you want to improve career prospects and be trained by excellent trainers with a thorough knowledge of the industry and train at your own pace then I would recommend this course."*

Gary Burrowes, BHPBilliton

*"This has been the best study process I have gone through and for advancing the career it is a must. The course content is extremely good and practical as I have baffled my engineers with some of the questions in the assignments making them question the content they actually studied."*

Henk Barnard

*"This is ideal for people such as myself that don't live or work in a city environment. It is the only viable way of increasing knowledge whilst working full time on a fly-in-out roster pattern."*

Brett Lapham

## VALUE plus!

As part of the incredible value we have built into this course, you also receive:

- Two places on any IDC Technologies public 2-day workshop\*

OR

- Two places at any IDC Technologies conference [conference component only, excludes workshop if available]\*

PLUS

- A library of 30 technical eBooks

All of this is valued at over US\$5000!

You may also be eligible for a tax deduction on your personal income tax – contact your tax advisor for more information.

\*to be used within 2 years of course enrolment and subject to availability. Your fee for this course must be up to date. The offer is for workshop or conference fee only and does not include travel, accommodation or other costs. The EIT is not responsible for cancellation or postponement of IDC Technologies workshops and conferences. Other conditions may apply at our discretion.

## EIT Accreditation Status

The Engineering Institute of Technology (EIT) is an institute for higher learning. It has emerged from its founding organisation, IDC Technologies, which is an international provider of practical, technical training. Since its conception in 1991, three hundred thousand engineers, technicians and technologists have been trained globally. The EIT has received recognition, endorsement and/or accreditation (varies by course and location) from authorising bodies based around the world. These include:

**IEEE** - The IEEE, based in the USA is the world's leading professional association for the advancement of technology, with more than 375,000 members in more than 160 countries. The EIT is an IEEE Continuing Education Provider.

**The Training Accreditation Council in Australia** - The national leader in the strategic management of the recognition and quality assurance of training.

**The Institute of Measurement and Control** in the United Kingdom - Britain's foremost professional body for the Automation Industry. The Advanced Diploma is recognised by the Institute of Measurement and Control as contributing to the 'initial professional development' required for eventual registration as Chartered or Incorporated Engineers. The Advanced Diploma is also approved by the Institute as providing CPD.

**South Africa - The Engineering Council of South Africa (ECSA)** which aims to promote a high level of education and training of practitioners in the engineering profession, has validated a large number of courses. The EIT has obtained validation for CPD Points from the SAIMechE (South African Mechanical Institute), COET (Chamber of Engineering Technology) and SAIEE (South African Institute of Electrical Engineers), who are Voluntary Associations recognised by ECSA (Engineering Council of South Africa). To view our list of validated courses and programs, visit ECSA's website [www.ecsa.co.za](http://www.ecsa.co.za) and refer to the CPD Activities. South African students who complete an EIT advanced diploma successfully can apply for recognition by SAQA, who have determined that the course is at Level 6 in the National Qualifications Framework (equivalent to National First Degree or Higher Diploma: [www.saqa.org.za/show.asp?include=focus/ld.htm](http://www.saqa.org.za/show.asp?include=focus/ld.htm)) in South Africa's educational system. However, in most cases formal individual recognition by SAQA is not required as the international validity and accreditation of this credential is very sound.

**Asia Pacific Utilities Group Supplier Management System** - EIT has achieved full registration on the Asia Pacific Utilities Group Supplier Management System (APUG SMS).

**AQF** - The Australian Qualifications Framework (AQF) is the national policy for regulated qualifications in Australian education and training. The Advanced Diploma of Electrical and Instrumentation (E&I) Engineering for Mining is an AQF accredited qualification.

For additional information please see <http://www.eit.edu.au/international-standing>.



To enrol please contact [eit@eit.edu.au](mailto:eit@eit.edu.au)

## COURSE STRUCTURE

This course is composed of 20 modules, covering 5 main streams:

- Power Engineering
- Communications
- Control
- Analytics and Management Systems
- Safety

The 20 modules will be completed in the following order:

- |  |   |
|--|---|
| 1. Electrical and Electronic Engineering Drawings      | 11. Leaky Feeder Systems                |
| 2. Electrical Power Distribution                       | 12. Wireless LANs                       |
| 3. Circuit Breakers and Switchgear                     | 13. Wireless Mesh Networks              |
| 4. Project Management                                  | 14. Field Buses                         |
| 5. Power Systems Protection                            | 15. SCADA Systems and OPC               |
| 6. Motor Control                                       | 16. Process Control Systems             |
| 7. Data Communications                                 | 17. Programmable Logic Controllers      |
| 8. Ethernet  | 18. Distributed Control Systems         |
| 9. TCP/IP and VOIP                                     | 19. Analytical and Management Systems   |
| 10. Terrestrial Microwave and Satellite Communications | 20. Personal Safety Systems And Devices |

For detailed information on the content and breakdown of modules, see pages 11 to 30

## Who Should Attend

This course would be ideal for you if you are seeking to get know-how and expertise in the mining industry and are an:

- Instrument and process control technician or technologist
- Instrument fitter
- Mining engineering supervisor
- Sales engineer
- Chemical, mining or mechanical engineer
- Electrical engineers and electricians
- Maintenance engineers and supervisors
- Design engineers
- Project managers
- Consulting engineers
- A recent graduate electrical, instrumentation or mechanical engineer

Even if you are highly experienced you will find this a great way to become familiar with mining technology as quickly as possible.

Gain cutting edge expertise with this prestigious, practical **ADVANCED DIPLOMA**



For more information or to enrol please contact us at [enquiries@eit.edu.au](mailto:enquiries@eit.edu.au)

## Presentation Format

The programme features real-world applications and uses a multi-pronged approach involving interactive on-line webinars, simulation software and self-study assignments with a mentor on call.

The course consists of 72 topics delivered over a period of 18 months. Presentations and group discussions will be conducted using a live, interactive software system. For each topic you will have an initial reading assignment (which will be delivered to you in electronic format in advance of the online presentations). There will be coursework or problems to be submitted and in some cases there will be practical exercises, using simulation software and remote labs that you can easily do from your home or office.

You will have ongoing support from the instructors via phone, fax and e-mail.

## Live Webinars

During the programme you will participate in 72 live interactive sessions/webinars with the instructors and other participants from around the world. Each webinar will be scheduled at 2 varying session times, so that you can select the one which is most convenient to you. Webinar times are only finalised after registrations close, as we need to know which time-zones all participants are based in before we can compile a schedule. Upon registration you will receive a questionnaire regarding your time availability. We guarantee that at least one session time, for each webinar, will fall into your preferred time slot.

## Prior Learning Recognition and Exemptions

The EIT can give you full or partial credit for modules where you can demonstrate substantial prior experience or educational background. An assessment fee may apply. If you wish to find out more please ask us for your copy of the policy for recognition of prior learning.

## Time Commitment for the Course

You will need to spend an estimated 6-10 hours per week. This includes the reading of the material prior to your attendance at each hour webinar (45 minutes with 15 minutes for discussion) and the time needed to complete assignments for submission. This time would be required to ensure the material is covered adequately and sufficient knowledge is gained to provide sound, enduring and immediately useful skills in engineering. The EIT operates almost all year long, so your studies will continue most weeks of the year to enable you to achieve the qualification in an accelerated time period when compared to a traditional semester-based system.

## Practical Exercises, Remote Labs and Assignments

You will participate in practical exercises using a combination of remote laboratories and simulation software, to ensure you get the requisite hands-on experience. This will give you a solid practical exposure to the key principles covered in the course and ensure you are able to put theory into practice.

As research shows, no matter how gifted and experienced an instructor (and we believe ours are some of the best worldwide), no one learns from an instructor only presenting course materials to them in a lecture format. It is only by the additional activities of hands-on exercises using simulation software, remote laboratories, practically based assignments and interactive discussion groups with both your peers and the instructor that you are able to internalize this knowledge, "take ownership of it" and apply it successfully to the real world. You should note that there is some degree of overlap between the practical sessions between the different units to reinforce the concepts and to look at the issues from different perspectives.

Traditional distance learning thus presents challenges in achieving these goals but we believe today with the modern e-learning technologies available combined with outstanding instructors that we can achieve these goals and give you an equivalent or indeed even better experience than on a traditional university campus. Practical sessions may be added, deleted or modified by the instructors to ensure the best outcome for students.

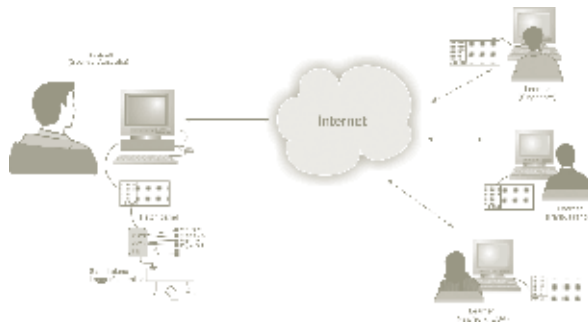

## Benefits of Live E-learning

- Attend lessons in a live, virtual classroom with your instructors and fellow students
- Upgrade your skills and refresh your knowledge without having to take valuable time away from work
- Receive information and materials in small, easy to digest sections
- Learn from almost anywhere - all you need is an Internet connection
- Have constant support from your course instructors and coordinator for the duration of the course
- Interact and network with participants from around the globe and gain valuable insight into international practice
- Learn from international industry experts
- Live interactive webinars, not just a 'book on the web'
- Receive an EIT Advanced Diploma of Electrical and Instrumentation (E&I) Engineering for Mining

## About the Engineering Institute of Technology (EIT)

The key objective of the Engineering Institute of Technology (EIT) is to provide an outstanding practical engineering and technology education; from Diplomas and beyond. The finest engineering lecturers and instructors, with extensive real engineering experience in industry, are drawn from around the world. The learning is gained through synchronous, online (e-learning) technologies.

The EIT offers awards in a growing array of engineering fields.

Many (perhaps, most) engineering faculties at universities and colleges experience a significant challenge delivering the course-work affordably and with excellence. The EIT achieves this using online based education - economical class sizes are attainable, international experts are engaged to instruct and remote laboratories and simulation software are employed.

The EIT is a sister company of the well known and reputable engineering training organisation, IDC Technologies. IDC has been operating for over 20 years, from offices throughout the world, delivering practical short courses to well over 300,000 engineers and technicians.

For more information or to enrol,  
please contact us at [enquiries@eit.edu.au](mailto:enquiries@eit.edu.au)

## Why EIT?

- Our lecturers are selected and recruited from amongst the top engineers/instructors in their field - worldwide. These presenters are highly skilled at presenting challenging concepts and ideas to students of varying levels and abilities.
- As shown in the detailed course prospectus, the courses are aimed at practising professionals giving hard-hitting practical know-how relevant to today's market and is aimed at people working in industry. We design and select Case Studies and practical exercises in the course based upon real-world business requirements. Feedback from the tens of thousands of students we have trained over many years has allowed EIT a unique understanding of real world business requirements and we have tailored the course accordingly.
- We have experience in training over 300,000 engineers and technicians throughout the world and have built up a library of outstanding reference materials which focus on what engineers and technicians need in their work today in industry and mining. The value of these references is considerable and they are a great asset to industry professionals. These reference materials are included in the cost of the course.
- The course content is challenging and designed for engineers and technicians already working in industry. We assume a general understanding of the demands of the workplace. A student without practical experience would be unsuited to the course.



## Course Fees

Your course fees include weekly webinars with leading engineering and technical experts, 30 technical eBooks, all course materials, software and postage, plus grading and support from the course coordinators and instructors. We provide payment options and can accept fees in a variety of currencies. Please contact your advisor for fees in an appropriate currency for your location.

## Comprehensive e-Books and Associated Documentation

You will receive 30 of our up-to-date technical e-Books to add to your library. Together these texts contain over 8000 pages of valuable know-how distilled from years of experience in presenting these courses throughout the world.

- 1) Electrical Drawings and Schematics
- 2) Practical Power Distribution
- 3) Safe Operation and Maintenance of Circuit Breakers and Switchgear
- 4) Practical Project Management for Engineers and Technicians
- 5) Practical Power System Protection for Engineers and Technicians
- 6) Practical Motion Control for Engineers and Technicians
- 7) Practical Troubleshooting and Problem Solving of Industrial Data Communications
- 8) Practical Troubleshooting and Problem Solving of Ethernet Networks
- 9) Practical TCP/IP and Ethernet Networking for Industry
- 10) Practical FieldBus and Device Networks for Engineers and Technicians
- 11) Practical SCADA and Telemetry Systems for Industry
- 12) Practical Process Control
- 13) Practical Programmable Logic Controllers (PLCs) for Automation and Process Control
- 14) Practical Data Communications & Networking for Engineers & Technicians
- 15) Practical Industrial Wireless for Engineers and Technicians
- 16) Practical Fibre Optics for Engineers and Technicians
- 17) Practical Troubleshooting and Problem Solving of Modbus Protocols
- 18) Practical Routers and Switches (including TCP/IP and Ethernet) for Engineers and Technicians
- 19) Practical Arc Flash Protection for Electrical Safety Professionals
- 20) Operation and Maintenance of Diesel Power Generating Plants
- 21) Troubleshooting, Maintenance and Protection of AC Electrical Motors and Drives
- 22) Practical Energy Efficiency, Design, Engineering and Auditing
- 23) Practical Earthing, Bonding, Lightning and Surge Protection
- 24) Fundamentals of Power Distribution and Power Systems – Hands-on Practical Analysis and Design
- 25) Electrical Maintenance for Engineers and Technicians
- 26) Wind and Solar Power - Renewable Energy Technologies
- 27) Practical Power Transformers: Operation, Maintenance and Testing
- 28) Practical Analytical Instrumentation in On-Line Applications
- 29) Best Practice in Process, Electrical and Instrumentation Drawings and Documentation
- 30) Practical Hazardous Areas for Engineers and Technicians



*Please Note: Students who choose to pay upfront will receive all 30 e-Books in advance. If you opt to pay by installments you will receive e-Books periodically throughout the course. e-Books are available in hard copy at 50% of the recommended retail price. Contact us for pricing details.*

## Entrance Requirements

This Engineering Institute of Technology advanced diploma is an accelerated, practical, work-oriented course. It is designed for engineers and technicians who have some background in the field. This includes those who have technical or 'trade' qualifications who want to move to the next career step, those with substantial relevant work experience who need to formalise and enhance their achievements, and those with higher level qualifications in a related field who wish to develop specialist knowledge. Practical work experience in related areas of engineering would help enormously. It would not be suitable for a student with no relevant work experience. We will review your enrolment application and may recommend pre-course studies if required.

## Advanced Diploma Preparation Course

If you are unsure if you have a strong enough grasp of the fundamental knowledge required for this course, or you simply want to refresh your skills and experience e-learning in a shorter course, we recommend that you consider the EIT's engineering studies preparation course. This intensive 4-month course covers the fundamentals of engineering maths, physics and chemistry. Please ask your advisor for the brochure. If you don't currently have an existing qualification and/or experience, please contact us for advice. Most important, however, is a determination to persist and complete this course.

On completion of this course, 50% of the course fees can be used as a credit towards your fee for an EIT Advanced Diploma course.

## Hardware and Software Requirements

All you need in order to join the webinars once registered for the course is an adequate internet connection, PC, speakers and a microphone. The software package and setup details will be sent to you prior to the course.

## We are Flexible With Your Commitments

We recognise that personal circumstances can make it difficult to complete the course in the time available. We will be flexible about the time you require to complete the course. You can "pause and restart" by joining a subsequent intake (a rejoining fee may apply). We will allow up to 3 years from your original commencement date to complete the course.

You can withdraw from the course at any time and receive a Certificate for the topics you have completed. However, completion of all 72 topics will earn you the EIT Advanced Diploma of Electrical and Instrumentation (E&I) Engineering for Mining.



## What Our Students Have to Say

QUOTES FROM PAST STUDENTS  
on the EIT 2009 SURVEY  
ON E-LEARNING  
to the following question:

What made you choose  
an EIT course(s)?

*"Good reputation, had attended good full-time courses previously."*  
Worley Parsons

*"Course facilitator CV, ...reputation, e-learning flexibility."*  
SMK, New Zealand

*"Content tends to practical and targeted."*  
MIPAC, Australia

*"Non-vendor specific training and lower course costs with online training capabilities."* Worley Parsons

*"The content of the course and the way the course was broken down were the key factors."* GEA Group

*"I can do those courses at my own free time which made it more convenient for me"*  
Iluka, Australia

*"Content was applicable to my job and industry. Taught by industry experts not academics. E-room delivery mode. Accreditation in various nations."*  
Sanofi Pasteur, Australia

*"Because it is specialist, and so many available courses."* Kacst, Saudi Arabia

*"Covered all my criteria and gave me recognised qualifications on completion."*  
Netafim

*"I took a previous course, IDC [associated organisation] is professional."* Cat Group

*"I have done other courses with IDC {associated organisation} and was happy with the service provided."* GHD

*"Had completed courses previously. Good content."* Woodside

*"I understood from friends that it is good quality."* Rio Tinto

*"Better choice of topic."* Rockwell RA

*"Believed to be good quality based on previous training courses I have done in person."* BHP Billiton, South Africa

*"It was referred to me by a colleague and I have attended seminars run by IDC before. The course that I am currently enrolled in also had all the outcomes I was looking for to further my career."* Rio Tinto

*"The course content was relevant to my work environment and practical."* Alcoa

*"I have done a few IDC courses in the past and found them to be very good and delivered by people with practical knowledge of the subjects."* Kalgold

*"It provides good online course delivery including its quality support structures"*  
OneSteel

*"Course interest and content."*  
ABB, Australia

*"The fact the I could do it online and it was in line with furthering my knowledge for work."* CAED, Australia

*"it ticked all the boxes ... quality, suitability, depth, length."*  
Powerco, New Zealand

*"Better choice of topic."* Rockwell RA

*"Course was visible and relevant."*  
Schneider Electric, UK

*"Convenience."* Rio Tinto

*"To be perfectly honest with the small amount of research on various courses I did the courses are generally the most relevant to my area of work. That's not to say they are perfect but they seem to be superior to others readily available in this part of the world."*

WEL Networks, New Zealand

*"Course content seems practical and applicable. I already have a BSc where the focus is on the theory."*

BHP Billiton, South Africa

*"Industry recognition and recommendation by colleagues."* Rio Tinto

*"Seemed the most convenient option, and it was!"* CPIT, New Zealand

*"Course content ease of study option."*  
Nestle, South Africa

*"The content of the course made up my mind."*

Transportadora de gas del Norte, Argentina

*"Their courses are standard and course material as well as lecture are okay."*  
Shell, UK

*"Its international recognition with body endorsing certification. Easy to attend lessons after work hours. Easy way of course payment."*  
Kinyara Sugar Ltd, Uganda

*"The most practical and technical offerings by the most qualified instructors for distance learning."* Encana Natural Gas

*"On line references, price, and various time frames available to sit in on the class. Also, one more important item was being able to converse with the instructor and class instead of working totally on my own."* Mitchell Technical Institute

*"Course content Accreditation of the training institution. Cost."* MODEC

*"Offer the correct course, timing and affordable cost."* Folec, Brunei

*"Possibly the most recognised online institution within my industry."*  
DRA, South Africa

# Frequently Asked Questions

## What are the advantages of studying online?

We know that many potential students have part or full-time employment as well as family commitments, so finding the time to study a classroom-based course is not always possible. Many students also have geographical, travel and time limitations and do not have an accessible institution or training provider. We have taken this into consideration and developed an affordable, flexible, online approach to training. This means that you can study from anywhere, with minimum downtime from work – but still have the necessary interactive learning experience. The software we use does not require very fast internet connection or a sophisticated computer. A basic connection and hardware are sufficient.

## What are the fees?

The EIT provides distance education to students located almost anywhere in the world – it is one of the very few truly global training institutes. Course fees are paid in a currency that is determined by the student's location. A full list of fees in a currency appropriate for every country would be too complex list here and, with today's exchange rate fluctuations, difficult to maintain.

To find out the fees for your location, contact us at [enquiries@eit.edu.au](mailto:enquiries@eit.edu.au).

## What do I need?

An adequate Internet connection, speakers and a microphone. A headset is recommended. The necessary software and course materials are provided by us.

## Doesn't it get boring? How can an e-Learning course be interactive?

Boredom can be a real risk in any form of learning; however, we use an interactive approach to our e-Learning – with live sessions (instead of recordings) for most presentations. The webinar software allows everyone to interact and involves participants in group work; including hands-on exercises with simulation software and remote laboratories where possible. You can communicate with text messages, or live VoIP speech, or can even draw on the whiteboard during the sessions. This all helps to keep you motivated and interested.

## What do live webinars involve?

These are live, interactive sessions over the Internet. You will join the instructor and other participants from around the world in an online 'virtual classroom' where you are able to watch a presentation, and communicate with the instructor and other students via audio, text messaging or drawing on the whiteboard. Each webinar is between 60 and 90 minutes in duration and the sessions are scheduled at 2 or 3 different times during the presentation day. This allows you to select the session which is most convenient.



Contact us!  
For any other enquiries,  
please contact us at  
[enquiries@eit.edu.au](mailto:enquiries@eit.edu.au)

## What if I cannot join or I miss a live webinar?

Webinars are recorded and available to students upon request. One requirement of the course is that you join at least 70% of the live sessions. The live webinars offer the opportunity to interact with the presenter and other participants from around the globe - an essential yet enjoyable part of the learning process.

Circumstances such as on-site work can make attendance difficult at times. These situations need to be clearly communicated with your e-learning coordinator. Feedback from the recordings may be required and assignment submission maintained.

## When will the sessions take place? When will I receive a webinar schedule?

The webinar schedule is not put together until after registrations close. The reason for this is that the course is promoted globally and we often have participants from several time zones. When you enrol you will receive a questionnaire which will help us determine your availability. When all questionnaires are returned we create a schedule which will endeavour to meet everyone's requirements.

Each webinar runs 2 or 3 times during each presentation day and we try our best to ensure that at least one session falls into your requested time frames. This is not always possible, however, due to the range of locations of both presenters and students. If you are unable to attend the webinars scheduled, we do have some options available. Contact the EIT for more details.

## Can I complete the course in less time?

Our courses actually require 'attendance' and participation at the live webinars. The interaction which takes place is an important part of the learning process. Our experience has shown that the interactive classes work exceptionally well and students are far more likely to stay motivated, enjoy the program, and complete the course successfully. See also 'What if I cannot join or I miss a live webinar?' In addition, accelerating the course would be quite onerous for most students.

## How much time do I need? How long is the course?

The course reading and assignments may consume anywhere from 5 to 10 hours per week. This will vary depending on the course subject matter and your existing knowledge.

The EIT does not use a traditional semester-based system, which means that you can complete the qualification faster without long breaks. Each advanced diploma course is delivered over an intensive 18 months. We do break for about 4 weeks per year for traditional festive seasons.

Contact us! For any other enquiries, please contact us at  
[enquiries@eit.edu.au](mailto:enquiries@eit.edu.au)

# International Expert Speaker Faculty

Your team of professional presenters and facilitators are drawn from experts in their field. They will work closely with you for the duration of the course.

## GUEST PRESENTER

**Dr. Peter Fuhr** PhD

Chairperson, Wireless Industrial, Networking Alliance, Co-Chair, ISA100 WG5, Wireless Coexistence and Interoperability, Congressional Panel on Nanotechnology, USA

Dr. Peter Fuhr has been involved in secure industrial wireless sensing systems for longer than he cares to admit. During his 20 years as a university professor, he embedded sensors into various structures worldwide ranging from buildings, dams, airplanes, hot air balloon, spacecraft, nuclear power plant containment vessels, even humans. Peter has published/presented over 700 technical articles pertaining to wireless, sensors, and secure SCADA systems. His pioneering work in networked sensor systems for structures earned him the Presidential Award for Excellence in Research. Segments of his research activities are featured in the SPIE Milestone Series on Fiber Optics.

Dr. Fuhr has served as the President and Chairman of the Wireless Industrial Networking Alliance and is the Distinguished Scientist for Oak Ridge National Laboratory. Dr. Fuhr chairs numerous standards and technical committees including, ISA100.5/6 Industrial Wireless Coexistence/Interoperability, ISA100.21 Industrial Real Time Location Services, ISA100.19 Wireless for Nuclear Applications; IEEE1451.7, IEEE 1777 (Provisional) Wireless for Electric Utilities; Congressional Panel on Nanotechnology; Subject Matter Expert for the Smart Grid. In addition he Chairs the Association for Advanced Agricultural Technology and has presented before the U.S. Congress on Secure SCADA and Industrial Wireless Automation Systems.



## PROGRAMME DESIGNER AND COURSE LEADER

**Deon Reynders** BSc Eng (Hons)(Elec), MBA

Deon has had over 25 years experience in automation, data communications (with a focus on industrial applications) and Ethernet TCP/IP networks. He has specific experience in Systems Engineering, Project Management and software and hardware development, and has been involved with efficiency studies (related to underground operations) in the gold mining industry in South Africa.

Currently he is retained as a consultant to industry in the TCP/IP, industrial Ethernet networking, OPC and the industrial data communications areas. Deon is a practical, hands-on person and a highly entertaining speaker. He has received excellent reviews from his thousands of course participants in regions ranging from Europe, North America, Africa and Australia. He takes great pride in demystifying difficult concepts and presents them in a simple-to-understand manner. He is a passionate, enthusiastic and knowledgeable professional engineer.



## COURSE PRESENTER

**John Lawrence** BSc (Hons) M.Sc B.Com (Hons)

In today's hyped up world, one is hesitant to describe anyone as 'outstanding', but John Lawrence has distinguished himself over the last 15 years with excellent course reviews.

John was extensively associated with the Diamond and Gold mining industries in Southern Africa, and has over 20 years of experience as a project and departmental manager for a multinational oil company, focusing on designing and managing the infrastructure of the telecommunications, data communications and IT systems.

In the past 5 years, John has worked extensively for a number of multi-national clients, managing projects including facilities management, budgeting and financial forecasting.

When John is not consulting or lecturing, he enjoys increasing his own skills by reading and writing about state-of-the-art technology topics and how to optimise Return On Investment (ROI) for the overall IT infrastructure. John is a dedicated professional who has trained engineers and technicians throughout the world.



## COURSE PRESENTER

**G. Vijayaraghavan** B.E. (Hons) Electrical

G.Vijayaraghavan is an electrical engineer with over 35 years experience in the Steel Industry and Engineering Consultancy.

He is the author of several of IDC's technical books including Practical Earthing, Bonding, Shielding and Surge Protection which has been published and sold internationally by Elsevier(UK).

He regularly designs training workshops for IDC and lectures on their behalf to engineers and technicians world-wide.

He is a very knowledgeable instructor and his courses are extremely interesting with many ideas, anecdotes and tips drawn from his rich experience.



# International Expert Speaker Faculty

## COURSE PRESENTER

**Geoff Bottrill** HNC, DMS, MIEE

Geoff has been working in the instrumentation, measurement and control fields for over twenty-five years and has spent the past fifteen years specialising in Hazardous Areas, Intrinsic Safety and Instrumentation Drawings. Geoff began his career at Kent Instruments, as a service engineer working in both the UK and East Africa. His experience ranges from systems design functions, on-site trouble shooting to technical and commercial customer support.

Recently Geoff has taken on the responsibility of mentoring engineers in training, in addition to the presentation of engineering workshops in the process control and measurement field. His positive interactive style to teaching has made him popular with course attendees worldwide.



## COURSE PRESENTER

**Dr Rodney Jacobs** NH Dip, M Dip Tech, BA (Hons), D Tech

Rodney has over 20 years experience in the gold mining industry, underground as well as specialising in Metallurgical operations in the Gold Plants. He has worked predominately in the instrumentation; process control and automation field, and is responsible for hardware and software designs associated with instrumentation. His areas of special interest include PLCs, SCADA systems, process control and programming. Having spent many years on the shop-floor, Rodney has built up a vast amount of hands-on practical experience, and is a past recipient of the N & Z award, which is one of the most prestigious awards, for South Africans in the field of instrumentation.

Rodney is currently active as a Consulting Engineer in the field of instrumentation, both to the mining industry as well as to other general engineering companies, which require specialised solutions. He has also lectured in Electronics, Electrical Engineering and Digital Systems, at a university level. Rodney feels that people are the most important asset of any organisation and has a qualification in Psychology to complement his Engineering knowledge and experience.

Rodney has presented numerous IDC workshops in the United States, England, Ireland, Scotland, Bahrain, United Arab Emirates, Iran, Vietnam, Australia, New Zealand, Malaysia and a great deal of sub-Saharan countries in Africa.



## COURSE PRESENTER

**Ian Verhappen** BSc, P. Eng, ISA Fellow, ISA Certified Automation Professional

Ian has been involved in digital communications since 1994 installing the first multi-vendor Foundation Fieldbus project in 1996. Since then, Ian has served as both a leading Project Engineer/Designer and an external/cold eyes review consultant for a number of companies and in pulp and paper, mining, food processing, water and wastewater, oil sands processing, petrochemical and refining industries. Ian is co-author, with Augusto Pereira, of ISA's popular "Foundation Fieldbus Pocket Guide". Also under Ian's guidance as editor, is the Foundation Fieldbus End User Advisory Council's "Engineering Design Guide, Foundation Fieldbus document AG-181". This is the definitive guide for the complete life cycle for Fieldbus projects. The "Guide" has been translated into German, Japanese, Chinese and Russian, demonstrating how widely it is used as the basis for many corporate and project specifications.

Ian is also an active volunteer with ISA, serving as Vice-President of the Standards and Practices 2005/6 and was the person responsible for the formation of the ISA-100 Industrial Wireless committee on which he continues to participate. Ian is also heading up the Fieldbus Foundation's High Speed Ethernet Remote I/O development team. Ian is known as a digital communications evangelist and his passion for the topic has taken him around the world to share his experiences.

Ian has accumulated over 20 years experience in oil sands mining where he used standard mining operations of slurry transport, flotation / separation cells and multiphase flow. He is also experienced in truck and shovel operations with associated crushing and solids transport including real time maintenance/operating data for this mobile equipment via wireless communications

Ian has the ability to explain technology in simple terms that can be understood by others without the same level of theory or experience, a rare quality!



# International Expert Speaker Faculty

## COURSE PRESENTER

**Terry Cousins** BSc (Elec Eng)

Terry Cousins was educated at La Salle College in Discovery, and obtained a BSc Electrical Engineering degree from Wits in 1977. He has over 30 years of experience in electrical power and distribution systems in various South African industries including the mining and steel sectors, with national companies such as ISCOR and Chamber of Mines Research.

He is currently a director of TLC Engineering Solutions who develops a wide range of instrumentation and measurement systems for industry. He also presents numerous courses on electrical power distribution and power quality, both in South Africa and abroad.

Terry is a Senior Member of the SAIEE, and a Member of the IEEE (USA) and has also served on the South African National Standards committee for power quality instruments (SANS 1816). Terry is an accredited professional with the Green Building Council of Australia, and has BComm and MBL degrees from UNISA.

With his extensive experience electrical engineering, you will walk away from this course with valuable know-how that you can apply immediately to your work.



## COURSE PRESENTER

**Andre du Plessis** Grad. Dip. Elect. Eng.  
Heavy Current., Elect & Mech Cert of Comp Mines

Andre has over 30 years experience in Electrical and Mechanical engineering in the mining industry., mainly underground and surface operations for gold, coal and platinum mines. Andre worked on various in-house projects and problem solving, in plants and smelting furnaces, including materials handling, battery locos and overhead trolley lines.

He has also had experience in maintaining and upgrading sub-stations, power distribution to concentrator plants, furnace, and mine sites. Some of his more notable projects were the installation of new 6.6kV cables down vertical winding shafts on gold mines and upgrading the OCBs to VCBs and doubling the capacity of Transforms for two 42MW furnaces for Anglo American mines in South Africa. Andre is a knowledgeable presenter with hands-on experience in a range of industries, which he is eager to share.

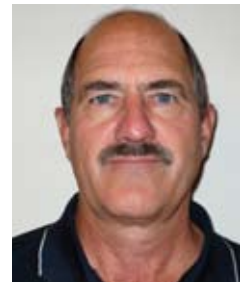

## COURSE PRESENTER

**Ivan Fair** PhD, PEng

Ivan Fair has extensive industrial and academic experience in telecommunications and data networking. He has been a research & design engineer for both Bell Northern Research (now part of Nortel Networks) and MPR TelTech Ltd. furthering their development of advanced fiber optic systems. It was during this industrial experience that he became interested the area of coding for data communication networks, and returned to the academic environment to focus on this topic. After receiving his doctorate, he joined Dalhousie University in Halifax before moving to the University of Alberta where he is now a Professor in the Department of Electrical and Computer Engineering. In addition to teaching communications and data networking courses, he supervises research projects and graduate students in these areas which has resulted in over 90 publications.

Ivan has held various administrative positions at university, and continues to be active in volunteer professional activities. He recently assisted Engineers Canada with their development of an Electrical Engineering syllabus, and is currently a member of the Board of Examiners for the Association of Engineers, Geologists, and Geophysicists of Alberta.



# Module 1: ELECTRICAL AND ELECTRONIC ENGINEERING DRAWINGS

## You will learn how to:

- Read drawings for electrical and electronic schematic diagrams
- Use symbols to represent electrical and electronic devices schematically
- Plan and execute schematic drawings using universally understood conventions
- Make the best use of CAD packages and their extensions
- Manage a drawing office and organize suitable workflow procedures
- Carry out version control, storage and retrieval of CAD drawings

## Overview

Drawings are used to communicate and share information between different teams of engineers; the design engineer who conceptualizes equipment or systems, the production engineer who plans the steps in manufacturing the required components and subsystems, the assembly engineer who puts the components together, the testing engineer who tests the complete system, the installation engineer who installs the system or equipment and the maintenance engineer who is responsible for its upkeep. To all these individuals, with diverse backgrounds and expertise, a drawing should convey precise and identical information. This calls for standardized methodologies, conventions and approaches in preparing drawings. This module covers all these aspects with respect to engineering drawings in general and electrical drawings in particular. Various types of electrical drawings and their application, the steps in planning a drawing, selection of drawing size and scale, use of standardized symbols etc. are described in detail with commonly used examples from industry practice.

## Practical Exercises

- Interpret the drawing of a typical circuit breaker schematic
- Represent the interlocking logic of a control schematic for a PLC
- Plan and create a drawing for an analog circuit with CAD software (CircuitMaker)

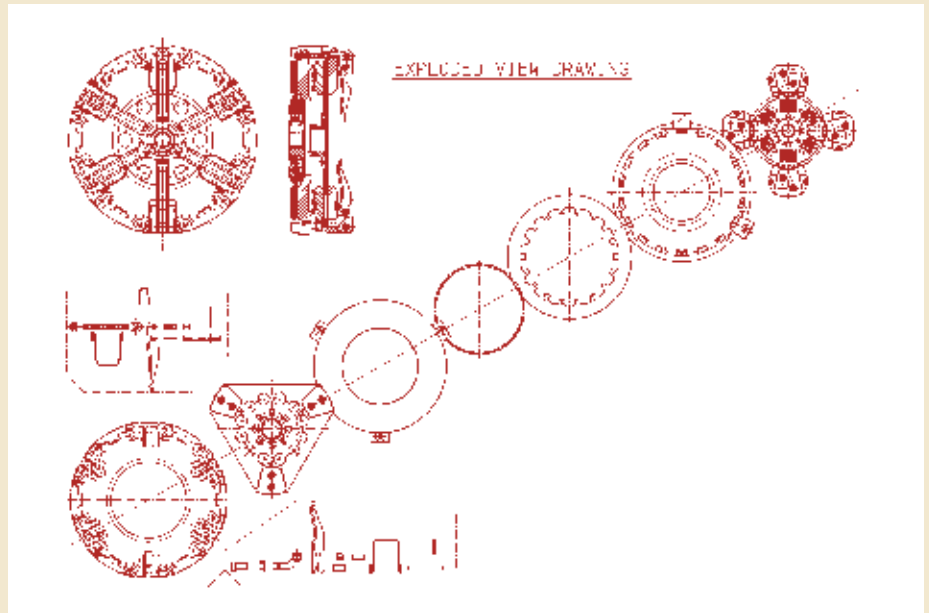

## THE PROGRAM

### Topic 1.1 - Introduction

- Introduction to engineering drawings
- Components of a drawing
- Drawing sizes
- Scales
- Symbols

### Topic 1.2 - Types of Diagrams

- Single line and 3-line diagrams
- Schematic diagrams
- Logic diagrams

### Topic 1.3 - Types of Diagrams cont.

- Cabling and wiring drawings
- Layout drawings

### Topic 1.4 - Computer Aided Drafting (CAD)

- 2D and 3D CAD applications
- Symbols, attributes and symbol libraries
- Automated Bill of Material generation from a CAD drawing
- Concept of layers and their use in sharing information
- Automation of drawing through programming
- Linking imagery with drawings - GIS related applications
- Management of drawings

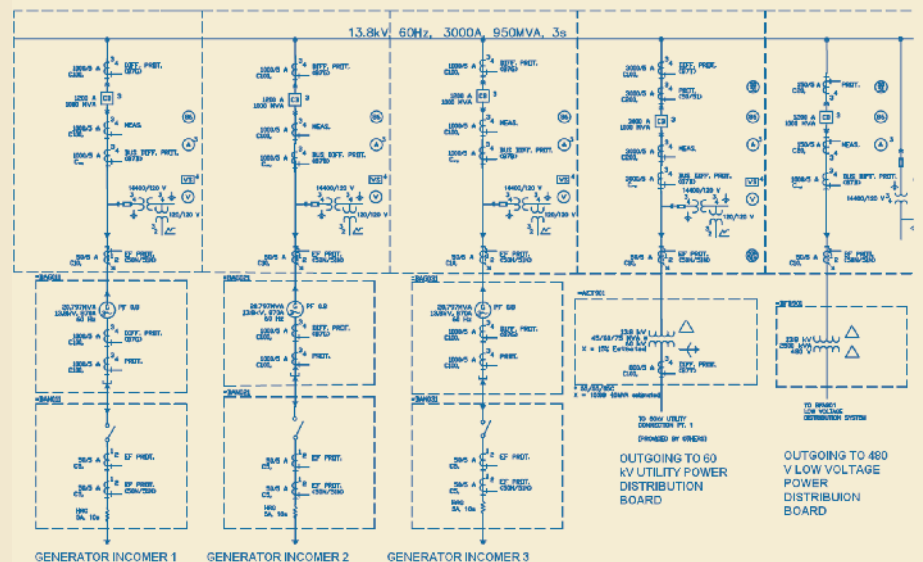

## You will learn how to:

- Determine short-circuit ratings
- Assess the influence of fault levels on switchgear ratings
- Select the correct type of switchgear for a specific application
- Recognize the different applications for various cable insulation types
- Know when and how to use single-core cables vs. three-core cables
- Specify correct power cable installation methods
- Correctly utilize and protect power transformers
- Assess and specify correct earthing/grounding throughout an electrical network
- Determine the need for Power Factor Correction

## Overview

Electricity distribution refers to the final stage in the delivery of electricity to end users. A distribution network carries electricity from the main transmission system, and delivers it to consumers. In general such a network includes medium-voltage (under 50 kV) power lines, electrical substations, pole-mounted transformers, low-voltage (under 1 kV) distribution wiring and, in some cases, electricity meters. This module will focus on the distribution systems for mines, both above and below ground.

## Practical Exercises

- Calculation of short-circuit currents
- Selection of switchgear (case study)
- Calculation of cable parameters with software (SolutionsElectrical)
- Power factor calculations

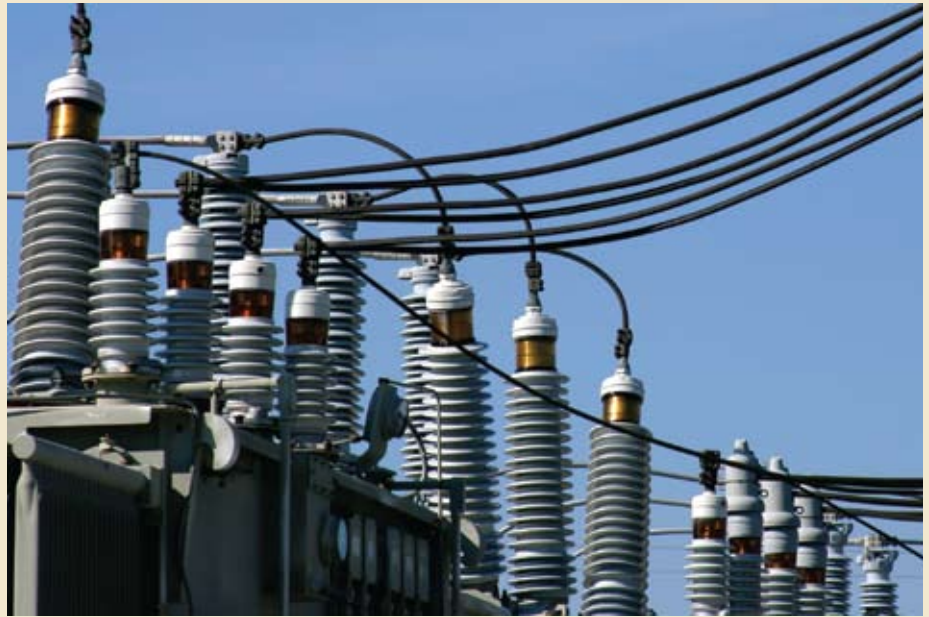
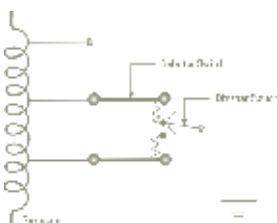

## THE PROGRAM

### Topic 2.1 - Introduction to Power Distribution

- Elements of a power distribution network
- Fundamentals of power distribution
- Basic design considerations
- Voltage considerations and improvement of voltage conditions
- Equipment generally used in power networks today
- Short circuit current calculations

### Topic 2.2 - Switchgear and Cables

- Medium voltage switchgear
  - Capabilities and ratings
  - Types of switchgear and applications
  - Insulation methods
  - Internal arc proofing
  - Protection relays
- Power cables
  - Insulation types and their applications
  - Cable losses and voltage drop
  - Cable ratings and short-circuits
  - Single-core vs. three-core cables
  - Mining cables
  - Installation, splicing and termination
- Connectors

### Topic 2.3 - Transformers and Power Quality

- Transformers
  - Classification and specifications
  - Connections and voltage taps
  - Transformer impedance
  - Insulation and cooling methods
  - Accessories and protection
- Compensation and power factor correction
  - Causes and effects of low power factor
  - Methods to improve power factor and benefits
  - Transients and capacitor switching
  - Resonance and harmonics
  - Protection of capacitor banks

### Topic 2.4 - Earthing/Grounding and Simulation

- Earthing/grounding
  - System and equipment earthing/grounding
  - Electrical safety earthing/grounding
  - Static earthing/grounding
  - Lightning protection
  - Ground resistance issues
- Computer simulation software
  - Load flow studies
  - Fault level studies
  - Equipment sizing
  - Motor starting studies

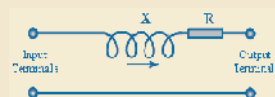

## You will learn how to:

- Selection appropriate types and ratings of switchgear
- Draw up purchase specifications
- Understand switchgear components (CTs, VTs, relays, cable terminations)
- Adopt safe operational policies including safety rules and safety documents
- Use diagnostic tools and test equipment

## Overview

Switchgear plays an important role in electricity distribution and its performance significantly affects the overall performance of the system. Failure to efficiently disconnect faults elsewhere in the network or failure in switchgear itself is costly, resulting in additional loss of supply, damage to equipment, and possibly fatal injury to personnel. It is therefore critically important that switchgear is operated and maintained correctly, within an overall asset management regime that is both economic and effective in securing a high level of system reliability. This module focuses on medium voltage switchgear, which comprises by far the bulk of switchgear on most electricity distribution systems. The emphasis is primarily on oil, air blast, SF6 and vacuum circuit breakers, but other forms of MV switchgear, for example ring main units and auto-reclosers, will also be discussed.

## Practical Exercises

- Case study: Design of a 132 kV switchboard

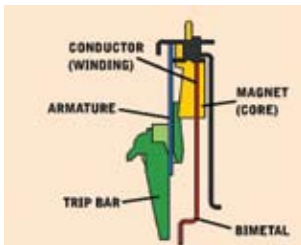

## THE PROGRAM

### Topic 3.1 - Switchgear Basics

- Principles of current interruption
- HV fuses
- Auto-reclosers
- Circuit breaker types
- Switchgear in association with disconnectors
- Switchgear standards

### Topic 3.2 - Switchgear Rating and Specification

- Switchgear ratings
- Switchgear ancillaries, measurement CTs, VTs, relays
- Cable terminations
- Substation and switch room layouts and design
- Testing methods

### Topic 3.3 - Safety and Operation

- General safety precautions, safety rules and personnel authorization
- Isolation in a circuit breaker context
- Safety documentation
- Safe working in a substation environment
- Safety interlocks
- Operation of modern switchgear: specific case studies (Westinghouse, Magrini, Reyrolle Pacific, Sprecher+Schuh SF6, NEBB)

### Topic 3.4 - Asset Management, Diagnostics and Maintenance

- Time and condition based asset management
- Asset management systems
- Switchgear diagnostics
- Principles of circuit breaker maintenance
- Maintaining oil circuit, vacuum and SF6 breakers

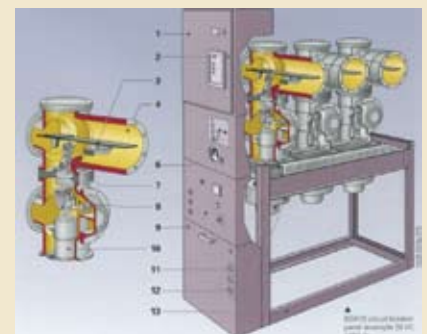
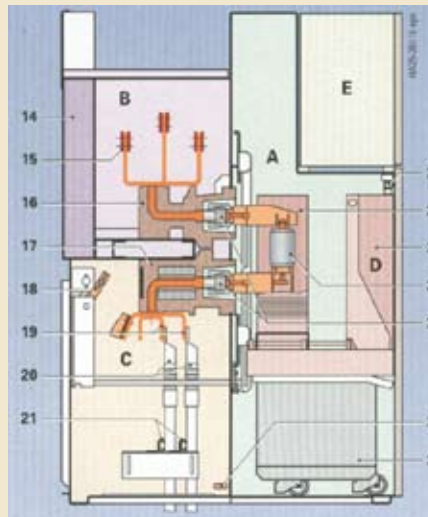

## You will learn how to:

- Create quality project plans
- Generate effective work breakdown structures
- Create PERT and GANTT charts and monitor your project effectively
- Define appropriate cost reporting mechanisms for your projects
- Define, analyse and manage the risks associated with your projects
- Introduce appropriate quality management procedures
- Keep your projects on track using Earned Value Analysis
- Exercise an appropriate leadership style and keep team members creative and motivated
- Avoid the pitfalls caused by a lack of understanding of relevant legal issues



## Overview

More and more engineering and technical professionals are making career transitions from product design into project management. This, however, requires formal training and a willingness to learn new skills. All the technical know-how in the world will not deliver a project successfully, i.e. with the required level of quality, within cost constraints and on time, without proper project management skills. Unfortunately very few engineering professionals have any degree of formal project management training, which results in a great deal of personal stress as well as cost blowouts and other woes, too often cited in the media. The lack of training often applies to the 'people skills' required for effectively leading the project team as well. To address this problem, these topics will focus on the critical project related activities such as work breakdown, scheduling, cost control and risk management and show how these can be performed with software to lighten the project manager's workload. The 'soft' (but equally important) aspects such as team leadership and contract law are also covered. All topics will be supplemented with practical exercises focusing primarily on the areas of electrical/electronic (including instrumentation) and mechanical engineering within the mining industry.

## Practical Exercises

- Create Work Breakdown Structure
- Schedule project (Pert and Gantt)
- Perform cost estimation and statistical contingency analysis (Monte Carlo)
- Perform Earned Value Analysis on project

## THE PROGRAM

### Topic 4.1 - Fundamentals and Time Management

- Project organizations, life cycle and phases
- Success criteria and critical success factors
- Work Breakdown Structures
- Precedence method of project network analysis
- Project schedules (PERT/GANTT charts)
- Resource allocation, analysis and levelling
- Progress monitoring and reporting

### Topic 4.2 - Cost and Risk Management

- Cost estimating
- Budgeting
- Financial and change control
- Cost reporting and variance analysis
- Value management
- Risk identification
- Risk analysis methods
- Risk assessment, treatment and monitoring

### Topic 4.3 - Quality and Cost Management

- Quality systems
- Project quality assurance
- Preparation of inspection and test plans
- Earned Value Management
- Budgeted vs. actual costs
- Cost and schedule variances
- Cost and schedule performance indices
- Final project costs

### Topic 4.4 - Project Team Management and Contract Law

- Situational leadership
- Organisation and project team cultures
- Teams: motivating factors
- Authority and power of the project manager
- Essential elements of contracts
- Factors destroying the legal force of contracts
- Termination of contracts
- Breach of contracts and liquidated damages

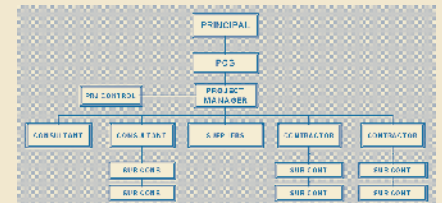
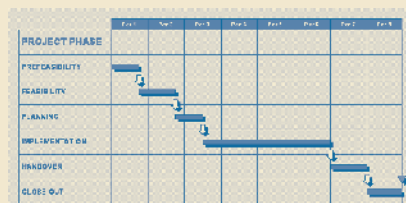



## You will learn how to:

- Specify protection requirements for motors
- Maintain electrical motors
- Specify speed control requirements for motors
- Understand essentials of motors and drives
- Detail the main issues with testing of motors
- Prevent, or at least minimize, motor bearing failure
- Troubleshoot and fix faults on motors and drives
- Interface control circuits of motors with PLCs/DCSs
- Reduce downtime on electrical motors
- Improve plant safety
- Improve plant throughput
- Reduce your spares usage and requirements

## Overview

It is estimated that electrical drives and other rotating equipment consume about 50% of the total electrical energy consumed in the world today. The cost of maintaining electrical motors can be a significant amount in the budget item of manufacturing and mining industries. This module will give you a thorough understanding of electrical motor protection, control and maintenance and provide you with the tools to maintain and troubleshoot electrical motors. You will gain a fundamental understanding of the protection, control and maintenance of electric motors and drives. Typical applications of electric motors in mining, manufacturing, materials handling and process control will be covered in detail.

## Practical Exercises

- AC motor control simulation
- DC motor control simulation
- Motor drive simulation

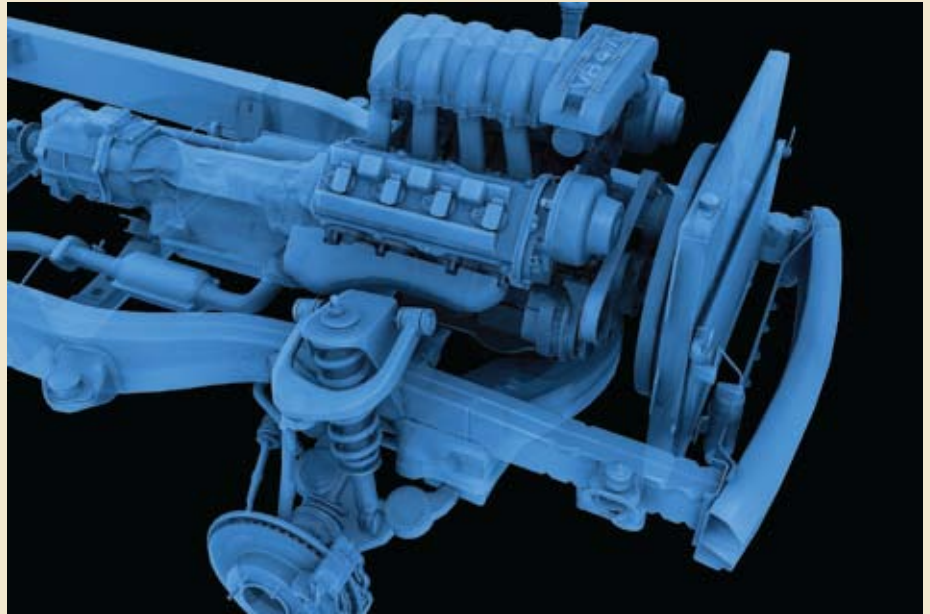

## THE PROGRAM

### Topic 6.1 - AC Motors

- Fundamentals of 3-phase AC motors
- 3-Phase induction motor construction and ratings
  - Squirrel cage
  - Wound rotor
- 3-Phase synchronous motor construction and ratings
- Mining applications

### Topic 6.2 - DC Motors

- Fundamentals of DC motors
- DC motor construction and ratings
  - Brushed
  - Brushless
- Mining applications

### Topic 6.3 - Variable Speed Drives (VSDs)

- Basic concept
- Mechanical, hydraulic and electrical VSDs
- Power electronic converters
- Electrical protection of VSD components
- VSD control systems

### Topic 6.4 - Other Control Methods and Drive Components

- Gearboxes
- Brakes
- Motor control
  - Phase vector drives
  - Direct torque controllers
  - SCR (thyristor) drives
  - PWM (chopper) drives
  - Ward-Leonard control
- Motor Control Centers (MCCs)

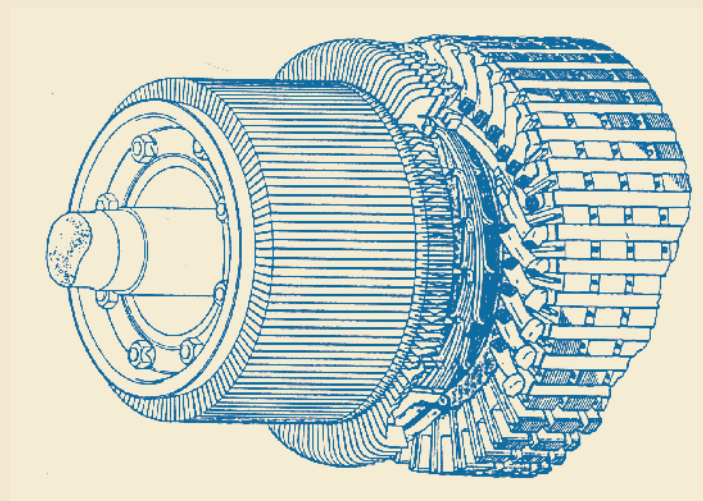

## You will learn how to:

- Describe the OSI and TCP/IP protocol stack models, and how they relate to each other as well as to the various wired and wireless communication technologies covered in this course
- Perform basic troubleshooting on RS-232 and RS-485
- Explain the difference between synchronous and asynchronous communication
- Explain the basics of protocols
- Perform basic protocol analysis on serial data communication systems
- Describe the advantages, disadvantages and application of the various conductive media (copper and fiber)

## Overview

This module introduces the 7-layer OSI and 4-layer TCP/IP models as overall frameworks in which to appraise all available wired and wireless communication technologies. It also describes the various conductive media (copper and fiber) that underpin these frameworks.

In addition, it describes some of the more common 'Layer 1' technologies such as RS-232 and RS-485. It also introduces the concept of protocols, their functionality, and their relationship with the OSI model. These protocols include asynchronous character-based (ASCII) protocols, asynchronous hexadecimal protocols and synchronous hexadecimal protocols.

## Practical Exercises

- RS-232 simulation and protocol analysis (Remote Lab)
- RS-485 2-Wire and 4-Wire simulation (Remote Lab)
- Fiber optic link design

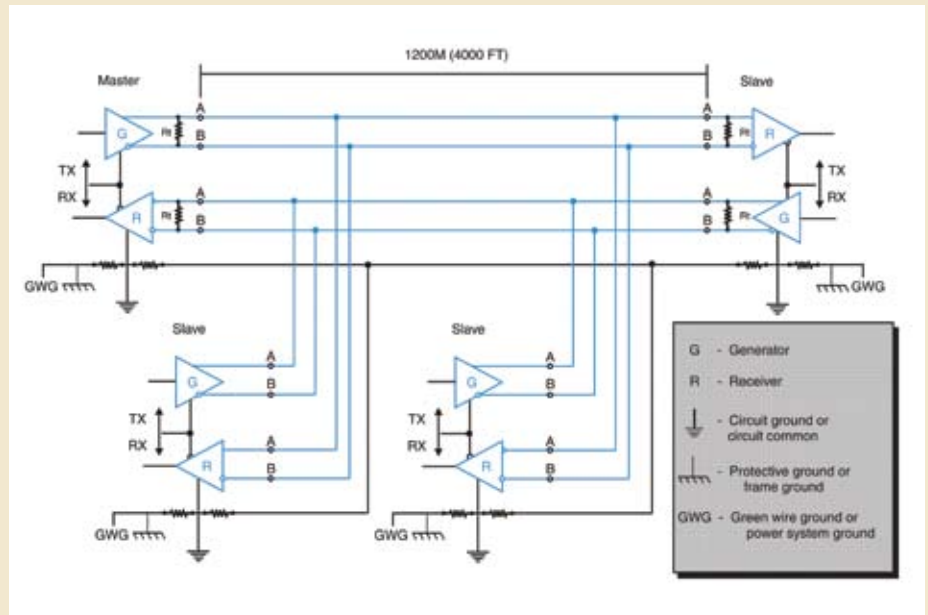
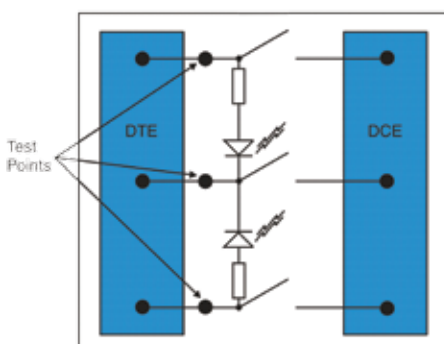

## THE PROGRAM

### Topic 7.1 - Data Communication Basics

- The 7-layer OSI and 4-layer TCP models
- Standards and regulatory bodies
- Number systems
- Encoding vs. modulation
- Physical vs. logical channels
- Full vs. half-duplex

### Topic 7.2 - Wired Serial Communication Standards

- Synchronous vs. asynchronous operation
- RS-232
- RS-422/423/485
- 4-20 mA
- Bell-202

### Topic 7.3 - Introduction to Protocols

- Definition of a protocol
- Protocols vs. the 4 and 7-layer reference models
- Modbus
- DNP3

### Topic 7.4 - Conductive Media

- Copper
  - Coax
  - UTP/STP
  - Connectors
- Fiber
  - Multi-mode fiber
  - Single-mode fiber
  - Connectors

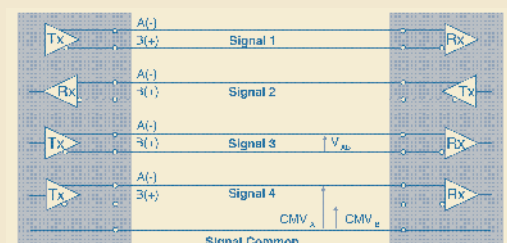
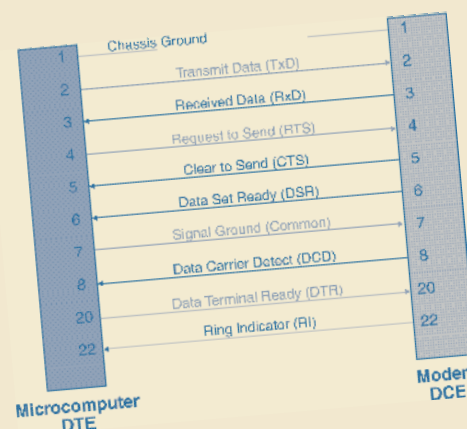

## You will learn how to:

- Distinguish between all the Ethernet variants
- Choose the most appropriate variant for your application
- Understand the issues addressed by 'Industrial' Ethernet
- Select the correct hardware (e.g. switches) for your application
- Design a basic Ethernet network
- Perform basic troubleshooting on Ethernet

## Overview

World-wide, and in virtually all industries, Ethernet has become the networking technology of choice. Mining is no exception and here Ethernet is increasingly to be found both above and below ground. It is being integrated with data as well as voice communications, and is even being integrated with Leaky Feeder and other wireless systems. It is even finding its way into Intrinsically Safe environments. This module takes an in-depth view at Ethernet, its method of operation, the various speed options and hardware components (switches, routers etc) and its application in the Mining industry.

## Practical Exercises

- Design basic switched network (star)
- Design basic switched Ethernet network with redundancy (ring)
- Configure a managed Industrial switch (Remote Lab)
- Capture packets and examine Ethernet headers (WireShark)



## THE PROGRAM

### Topic 8.1 - Legacy Ethernet

- Ethernet II vs. IEEE 802.3
- Variants (10Base5/2/T)
- Medium Access Control (CSMA/CD)
- MAC addresses
- Frame format

### Topic 8.2 - Higher-speed Ethernet

- Fast (100 Mbps) Ethernet variants
- Gigabit Ethernet variants
- Ten Gigabit Ethernet
- Full-duplex and auto-negotiation

### Topic 8.3 - Networking Components

- Repeaters/ hubs
- Bridges/ switches
- Routers/gateways
- Terminal servers/ media converters
- Switch applications
  - VLANs
  - QoS
  - Switched rings

### Topic 8.4 - Industrial Ethernet

- Packaging
- Cabling and connectors
- Power over Ethernet (PoE)
- Intrinsically Safe Ethernet (IECEX.ia)
- Determinism
- Mining applications

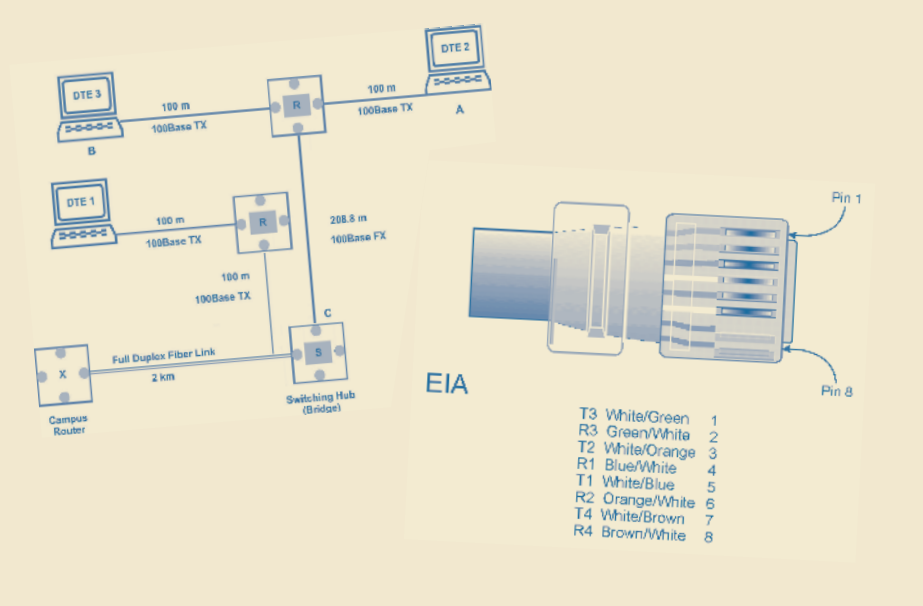
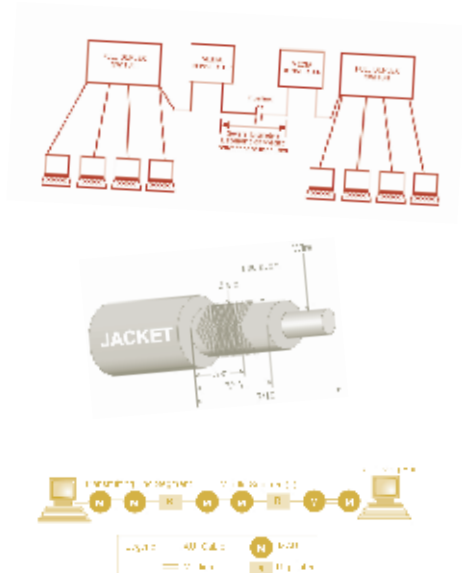

## You will learn how to:

- Perform IP configuration on IP devices
- Check TCP connections
- Use TCP/IP utilities for troubleshooting
- Use a protocol analyzer for troubleshooting
- Explain the basics of VoIP

## Overview

The TCP/IP protocol suite was originally designed for what was to become the Internet, but it has since been embraced by Industry, world-wide, because of its open (non-proprietary) nature and its robustness. It is therefore also ubiquitous in the mining industry, both above and below ground and on wired as well as wireless systems. In addition, there has been a rapid convergence between conventional voice telephony systems and networking (such as TCP/IP over Ethernet), with the result that Voice over IP (VoIP) is becoming commonplace in mines.

## Practical Exercises

- IP configuration (IP addresses, Subnet Masks, Default Gateways)
- Header analysis with Wireshark (IP/TCP/UDP)
- Observation of TCP connection (Wireshark)
- Use of built-in TCP/IP and Windows-based utilities (IP address and port scanners/trace utilities)
- Troubleshooting/packet sniffing VoIP packets on a routed network (Remote Lab)

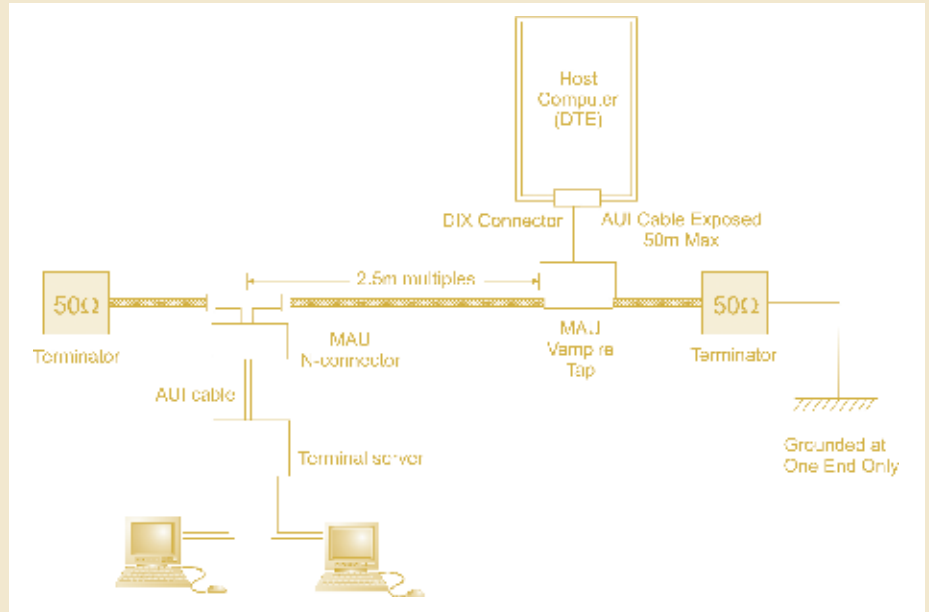
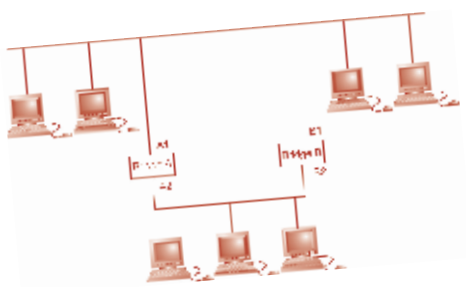

## THE PROGRAM

### Topic 9.1 - Internet Layer Protocols

- IPv4
  - Header structure
  - Addressing concepts
  - Basic routing principles and NAT
  - ARP
  - ICMP
- IPv6
  - Header structure
  - Addressing concepts

### Topic 9.2 - Transport Layer Protocols

- TCP
  - Header structure
  - Ports and sockets
  - Connection setup and teardown
- UDP

### Topic 9.3 - Application Layer Protocols and Utilities

- FTP
- HTTP
- BootP
- DHCP
- Telnet
- SSH and SSL
- Utilities (ping, arp, tracert)

### Topic 9.4 - Voice over IP (VoIP)

- Codecs
- RTP and RTCP
- H.323
- MGCP and SIP
- QoS issues
- Mining applications

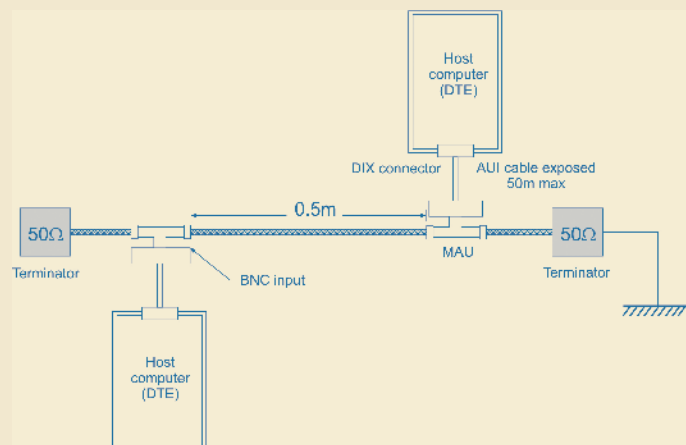

You will learn how to:

- Perform site selection based on given criteria
- Generate terrain maps/path profiles (manually and online)
- Determine mast/tower heights based on Fresnel Zone clearance
- Calculate link power budgets
- Select appropriate components (transceivers, antennas, etc)
- Apply computer-based propagation models and network planners
- Use this knowledge to design specific applications such as long-distance leased-line replacements, wireless Ethernet backhauls or wireless Ethernet bridges
- Use satellite services for communications in remote locations



Overview

Terrestrial microwave links, in either Point-to-Point (PtP) or Point-to-Multipoint (PtMP) configurations, employ earth-based transmitters and receivers, and are frequently used to transmit signals in situations where it would be impractical to run cables. The frequencies used are typically in the 800 MHz-5 GHz range, although 60-80 GHz links for backhauls are not uncommon. This limits all communications to line-of-sight, with or without intermediate repeaters. In most cases the unlicensed ISM bands are used, which simplifies installation. However, the EIRP (Effective Isotropically Radiated Power) at the antenna is still regulated by the relevant body such as the FCC in the USA and ACMA in Australia. In mining applications, wireless links are often used between sites although satellite services might be required in locations where a terrestrial wireless infrastructure does not exist.

Practical Exercises

- 3D terrain mapping for given path (online or software)
- Mast height determination
- Complete link design, including antenna selection for
  - 2.4 GHz long-distance wireless Ethernet link
  - 80 GHz Gigabit Ethernet wireless backhaul
  - 60 GHz Gigabit Ethernet wireless inter-building bridge

THE PROGRAM

Topic 10.1 - Wireless Basics

- Frequency bands and associated propagation methods
- Spread Spectrum (FHSS, DSSS)
- UWB
- Amplitude Modulation (AM, SSB, DSB)
- Phase modulation (PM, BPSK, QAM)
- Frequency modulation (FM, FSK)

Topic 10.2 - Terrestrial Link Design

- Path profile and mast height calculation
- Link budget
- Availability vs. fade margin
- Frequency and transmit power issues
- Antenna and feeder choices

Topic 10.3 - Terrestrial Applications

- Point-to-Point vs. Point-to-Multi-Point considerations
- Multiplexers
- Wireless Ethernet modems
- Wireless Ethernet range extenders
- Telemetry
- Wireless backhaul (linear and ring topologies)
- Mining applications

Topic 10.4 - Satellite Systems

- Satellite basics
- Very Small Aperture Terminal (VSAT)
- Satellites for telemetry
- Satellites for tracking
- Satellites for communications
- Mining applications

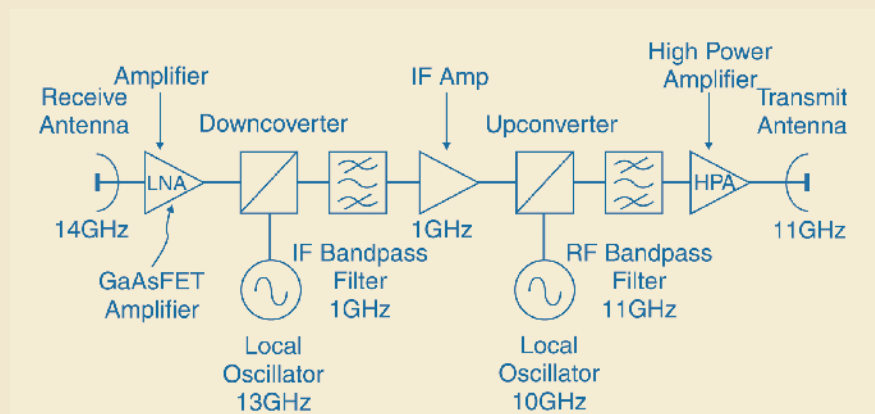

You will learn how to:

- Explain the concept of Leaky Feeder operation
- Select appropriate feeder cable
- Design a basic Leaky Feeder system with commercially-available components

Overview

Leaky Feeder is a communications system used in underground mining and other tunnel environments. It consists of a coaxial cable run along passageways, which emits and receives radio waves. The cable is 'leaky' in that it has gaps in its outer conductor along its entire length to allow signal to leak into or out of the cable. Because of this leakage, amplifiers are inserted at regular intervals to boost the signal back to operational levels. In recent years Leaky Feeder systems have been augmented with Ethernet, so that data and even voice (VoIP) can be accommodated.

Practical Exercises

- Designing an underground Leaky Feeder system based on commercially-available components

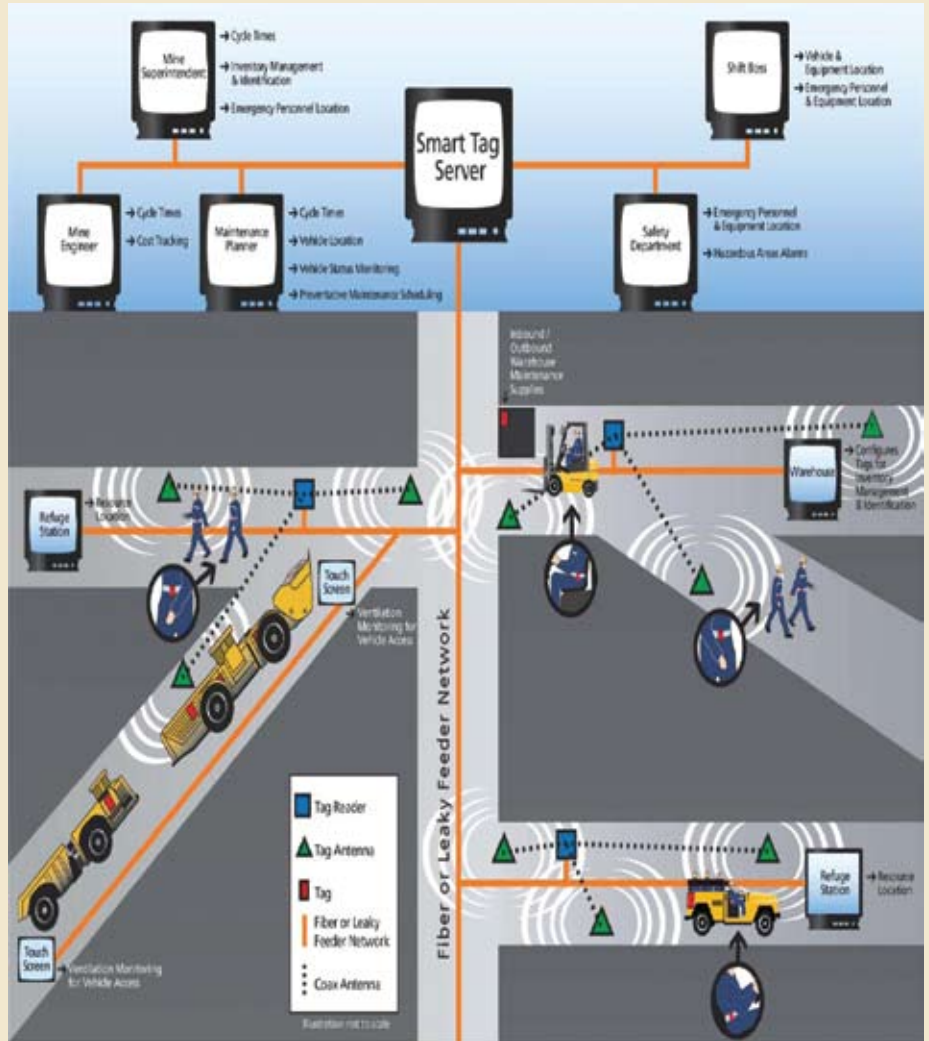

Copyright ©1999-2008 Varis Mine Technology Ltd

THE PROGRAM

Topic 11.1 - Leaky Feeder Theory

- Leaky feeder concept
- Typical system specifications
- Topologies
- Leaky coax
- System components

Topic 11.2 - Leaky Feeder Implementation

- VHF vs. UHF
- Intrinsic safety issues
- Ethernet over leaky feeder
- Voice and data over leaky feeder
- Mining applications



You will learn how to:

- Describe the inherent operating mechanism (frame structure, medium access control etc.) of IEEE 802.11 WLANs
- Predict the performance of the various implementations in terms of raw and actual data speeds
- Compare various 'Industrial WLAN' offerings in the marketplace, and understand their differences from conventional WLANs
- Design a basic industrial WLAN with Access Points and Clients, with or without redundancy considerations
- Perform basic configuration of an industrial AP

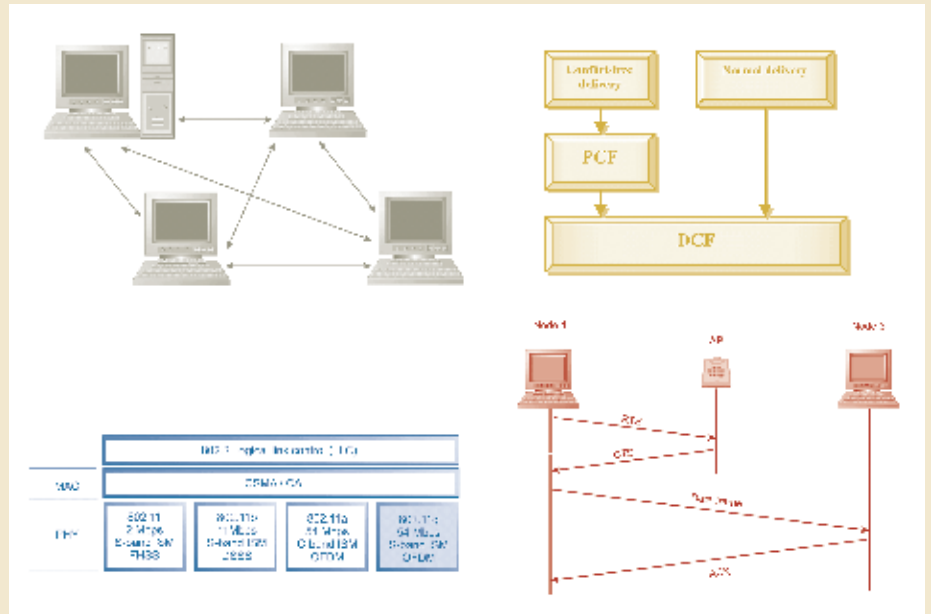

Overview

A Wireless Local Area Network (WLAN) links devices via a wireless infrastructure (typically one or more Access Points) and often provides a connection to the wider Internet through a router. This gives users the mobility to move around within a local coverage area whilst maintaining their connection to the network. WLANs have become popular in the home due to ease of installation and the increasing popularity of laptop computers. In industrial applications they simplify the deployment of movable client devices (e.g. on fork-lift trucks in warehouses) and eliminate the need for costly wiring.

In mining applications WLANs are increasingly being deployed underground, and are used for data as well as voice management and other services such as RFID tagging for vehicle and personnel management.

Practical Exercises

- Setting up Industrial Access Point (AP) (remote lab)
- Configuring two Industrial APs as a wireless bridge (remote lab)
- Capturing packets 'from the air' with Wireshark
- Design of mining WLAN with redundancy and fiber backhaul

THE PROGRAM

Topic 12.1 - WLAN Concepts

- Access Points (APs)
- Ad-hoc vs. Infrastructure mode
- Basic and Extended Service Sets (BSSs, ESSs)
- Wireless bridging
- Client roaming (MAC-and IP-level)
- Association and authentication
- Distribution Systems

Topic 12.2 - WLAN Standards/Amendments

- Brief overview of the IEEE802.11 standards and amendments
- IEEE 802.11a
- IEEE 802.11b
- IEEE 802.11g
- IEEE 802.11n
- Co-existence between 'b', 'g' and 'n'.

Topic 12.3 - Industrial Wireless LANs

- Industrial Access Points (APs) and Clients (ACs)
- IEEE802.11h (Spectrum and Transmit Power Management Extensions.)
- Redundancy
- Wired vs. wireless backhaul/distribution systems
- Mining application areas
- Commercially available WLAN systems for Mining

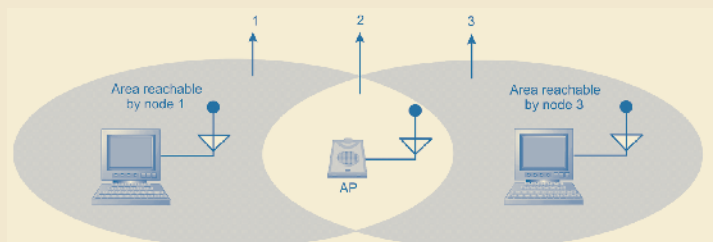
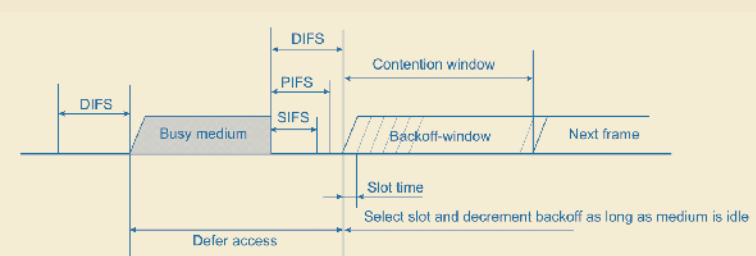

You will learn how to:

- Explain the basics of mesh networks in general
- Explain the specifics of IEEE 802.11 (Wi-Fi) based mesh networks
- Compare commercially-available wireless mesh solutions for mining applications

Overview

A Wireless Mesh Network (WMN) is a communications network made up of wireless nodes organized in a mesh topology, and can be seen as a special type of wireless 'ad hoc' network. WMNs usually consist of mesh clients, mesh routers and gateways. The mesh clients may include sensors, flow controllers, laptops, mobile phones and other wireless devices, depending on the application, while the mesh routers forward traffic to and from the gateways which may (optionally) connect to the Internet or to a larger wired network. The coverage area of the wireless nodes working as a single network is sometimes called a mesh cloud. A mesh network is reliable because of redundancy. All nodes communicate with each other directly or through intermediate nodes. When one node can no longer operate, the rest of the nodes will reconfigure around it, and still communicate with each other, directly or indirectly. Wireless mesh networks can be implemented with various wireless technologies including IEEE 802.11, IEEE 802.15.4, or proprietary variations of the aforementioned. Recent years have seen more and more mesh systems in mining applications, especially on open mines.

Practical Exercises

- Access to IEEE 802.15.4-based wireless flow controller (remote labs)
- Comparison of various IEEE 802.11 Industrial mesh implementations for mining applications
- Configuration of security settings on IEEE 802.11 Access Point

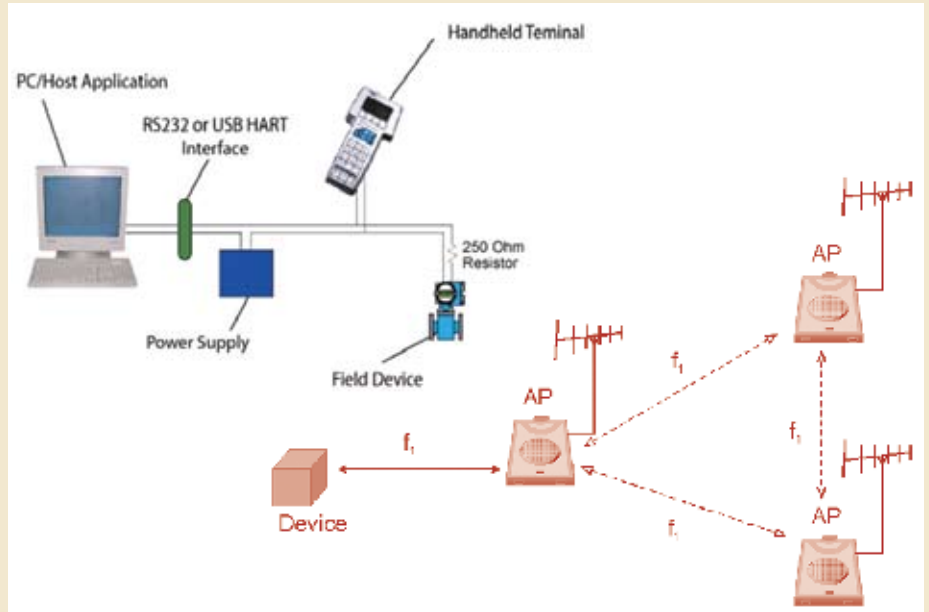

THE PROGRAM

Topic 13.1 - Mesh Basics

- Single radio mesh
- Dual radio mesh
- Multi-radio mesh
- Bridging mesh with wired or wireless
- Mesh routing algorithms
- Gateways
- IEEE802.11-based mesh

Topic 13.2 - Mesh Implementations

- Proprietary mesh implementations
  - Motorola
  - Cisco
  - Proxim
  - Strix
  - SmartMesh
  - Mini-mesh
- Commercial and industrial applications

Topic 13.3 - Wireless Security

- Firewalls
- VPNs
- Authentication
- Encryption
  - AES
  - SecNet 11

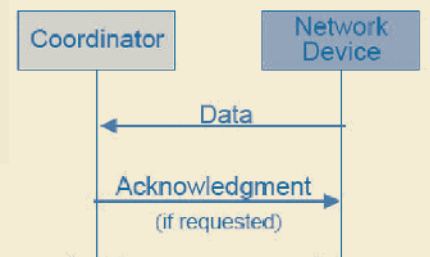
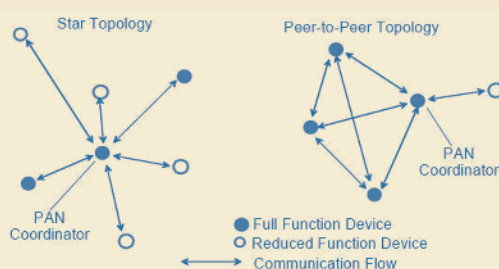

You will learn how to:

- Identify mining applications that can be automated with a field bus
- Be aware of the pros and cons of the various field bus offerings
- Select the most appropriate system for your application
- Perform basic diagnostics on various field buses

Overview

Profibus is a standard for field bus communication in automation technology and was first promoted (in 1989) by the German Department of Education and Research. Profibus DP uses RS-485 or fiber optics at the Physical Layer, and Profibus PA. DeviceNet is a field bus used in the automation industry to interconnect control devices for data exchange. Typical applications include information exchange, safety devices, and large I/O control networks. The HART protocol (Highway Addressable Remote Transducer protocol) is a digital industrial automation protocol. It's most notable advantage is that it can communicate over legacy 4-20 mA analog instrumentation wiring, sharing the pair of wires used by the older system. It uses Bell 202 signaling over a current loop. Foundation Fieldbus is an all-digital, serial, two-way communications system, similar to Profibus PA, that serves as the base-level network in a plant or factory automation environment. All these systems are used in the Mining industry, and also perform safety functions.

Practical Exercises

- Remote diagnostics on DeviceNet system (remote labs)
- Remote diagnostics on WirelessHART device (remote labs)
- Packet (telegram) diagnostics on Profibus simulator (remote labs)

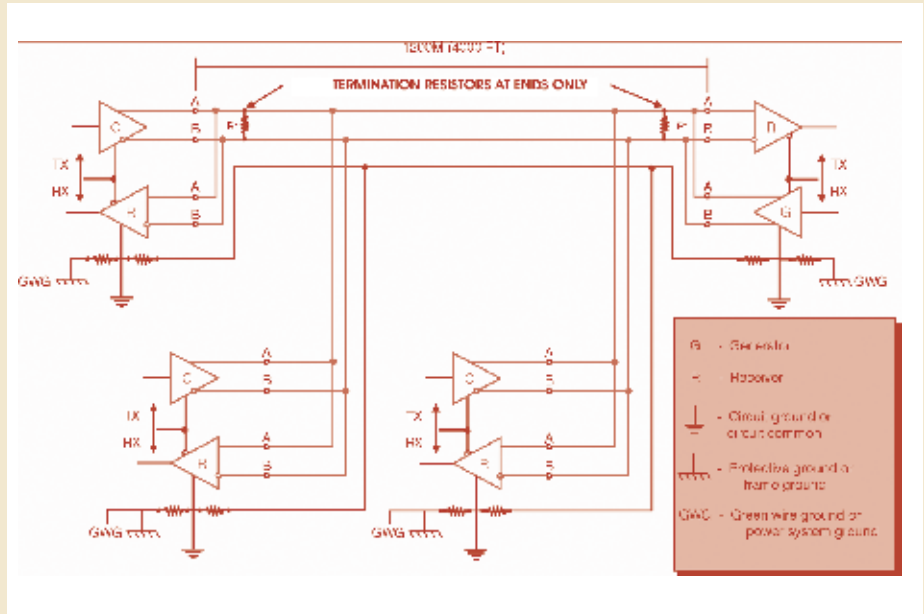
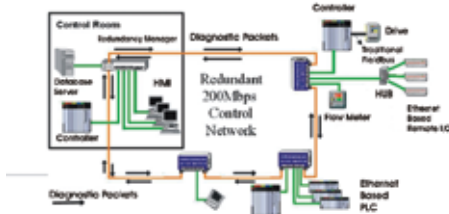

THE PROGRAM

Topic 14.1 - HART & AS-i

- What is a field bus?
- Field bus standards
- HART
  - The HART concept
  - Media, physical layer and topologies
  - Mining applications
- Actuator Sensor-interface (AS-i)
  - The AS-i concept
  - Media, physical layer and topologies
  - Mining applications

Topic 14.2 - DeviceNet

- Media
- Supported topologies
- Physical layer implementation
- Message structure
- Medium access control
- Device power
- Mining applications

Topic 14.3 - Profibus DP/PA

- Media
- Supported topologies
- Physical layer implementation
- Message structure
- Medium access control
- Device power
- Mining applications

Topic 14.4 - Foundation Fieldbus

- Media
- Supported topologies
- Physical layer implementation
- Message structure
- Medium access control
- Device power
- Mining applications

Topic 14.5 - Ethernet, Wireless and Safety on Field Buses

- Ethernet-based field buses
  - Ethernet/IP
  - ProfiNet
  - Foundation Fieldbus HSE
- Wireless extensions to field buses
  - WirelessHART
  - Wireless Profibus
  - Wireless DeviceNet
- Safety systems
  - DeviceNet Safety
  - ProfiSafe
- Mining applications

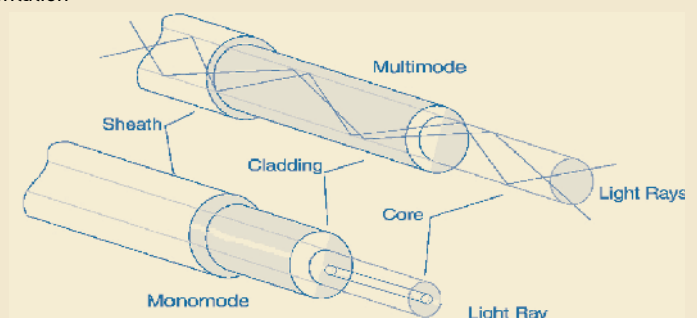

You will learn how to:

- Design a basic SCADA system
- Choose a suitable WAN link from your local Service Provider
- Choose an appropriate device for your SCADA data acquisition
- Integrate OPC with your SCADA application

Overview

SCADA has traditionally been used to create a window into the process of a plant, or to gather data from devices in the field, but now the focus is on integrating this process data into the actual business, and using it in real time. The current emphasis is on using open communication protocols such as IEC 60870, DNP3 and TCP/IP, and commercial off-the-shelf (COTS) hardware and software to keep the costs down. This module covers four major aspects of SCADA, namely (1) the overall SCADA system design, (2) the long-distance WAN links that convey data from the point of acquisition to the central station, (3) the systems and methods of remotely acquiring plant data, and (4) OPC, which is increasingly used in SCADA applications.

Practical Exercises

- Design of a SCADA system architecture
- Setting up an OPC Data Access server
- Using OPC to access SCADA system data
- Using OPC to build simple SCADA Human-Machine Interface



THE PROGRAM

Topic 15.1 - SCADA Basics

- SCADA hardware
- SCADA software
- Human Machine Interfaces (HMIs)
- SCADA networking
- Typical SCADA system topologies
- Good practice for SCADA networks

Topic 15.2 - Wide Area Network (WAN) Technologies

- Landlines
- Digital hierarchies, T1 and E1
- X.25
- Frame Relay
- ATM
- SDH/Sonet

Topic 15.3 - Data Acquisition

- Data acquisition devices
- SDI-12
- Linking data acquisition devices to the central station
- Signal sources
- Signal conditioning
- Digital I/O
- Analog I/O

Topic 15.4 - OPC

- The role of OPC in SCADA systems
- DCOM infrastructure
- (.NET) infrastructure
- OPC specification structure
- Legacy specifications: DA and AE
- Unified Architecture (UA)
- Typical OPC applications

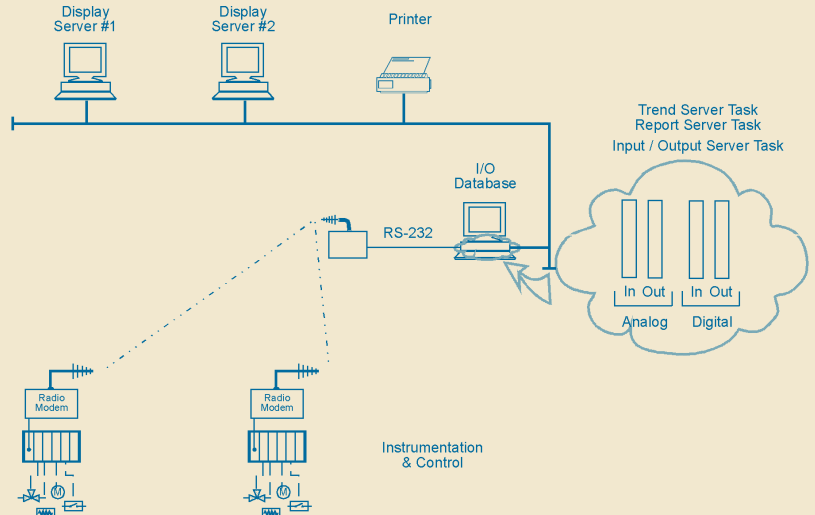
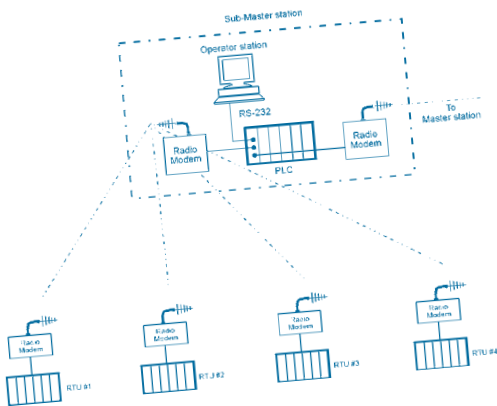

You will learn how to:

- Tune PID control loops
- Connect cascade loops
- Explain cascade loops and feed-forward control
- Correct long dead-times in a loop
- Specify and design the analog loop requirements for a plant using PID control
- Identify and apply the essential building blocks in automatic control
- Explain concepts used by major process control equipment vendors

Overview

To succeed in process control, a designer must first establish a good understanding of the process to be controlled. Since we do not wish to become too deeply involved in the process itself, we need to find a way of simplifying the representation of the process. This is done by adopting a technique of block diagram modeling of the process.

All processes have some basic characteristics in common and, if we can identify these, the job of designing a suitable controller is relatively easy. The trick is to make a reasonably accurate mathematical model of the process and use this model to find out what typical control actions we can use to make the process operate at the desired conditions.

The first part of this module deals with the modeling process, resulting in a system block diagram. From this analytical result an accurate selection of the type of measuring transducer as well as the final control element can be made. The rest of the module deals with other aspects of Process Control, namely the controller(s), functions, actions and reactions, function combinations and various modes of operation.

Practical Exercises

Various control simulations using PC-ControlLAB software. These include:

- Introduction to basic open loop control
- Introduction to basic closed loop control
- Proportional (P) control
- Integral (I) control
- Proportional and Integral (PI) control
- Derivative (D) control
- Introduction to stability aspects
- Identification of process characteristics
- Tuning of open loop control systems
- Tuning of closed loop control systems
- Cascade control
- Dead-time compensation in feedback control



THE PROGRAM

Topic 16.1 - Process Control I

- Basic definitions and terms used in process control
- Process modeling
- Process dynamics and time constants
- Proportional, integral and derivative control modes
- Process management and transducers
- 'Smart transmitters'

Topic 16.2 - Process Control II

- Basic principles of control valves and actuators
- Fundamentals of control systems
  - On-off control
  - Modulating control
  - Open loop control
  - Closed control loop
- Stability and control modes of closed control loops

Topic 16.3 - Process Control III

- Digital control principles
  - Proportional control
  - Integral control
  - Derivative control
- Real and ideal PID controllers
- Tuning of PID controllers in both open and closed loop

Topic 16.4 - Process Control IIII

- Process diagrams
- Concepts and applications of feed-forward control
- Combined feedback and feed-forward control
- Long process dead-time in closed loop control and the Smith predictor
- Basic principles of Fuzzy Logic and Neural Networks
- Self-tuning Intelligent Control and statistical process control
- Advanced Process Control (APC) in the mining industry

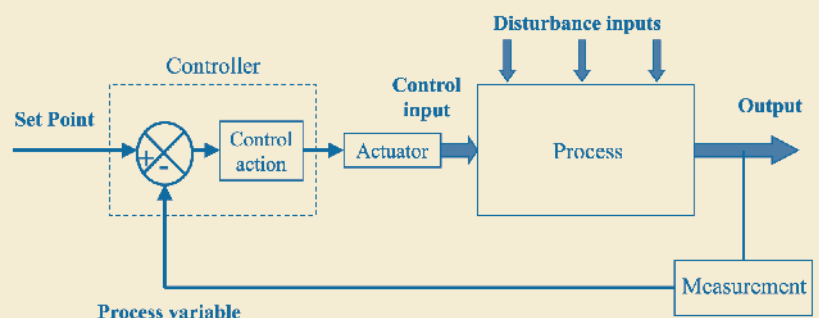

You will learn how to:

- Specify PLC hardware and installation criteria
- Describe PLC software structure
- Write medium-level PLC programs (using ladder logic)
- Troubleshoot a typical PLC system
- Specify PLC systems

Overview

This module provides up-to-date information on the application of PLCs to the automation and process control of plants and factories. It is suitable for people who have little or no previous exposure to PLCs, but expect to become involved in some or all aspects of PLC installation. You will receive practical advice from experts in the field in order to assist you to correctly plan, program and install a PLC with a shorter learning curve and more confidence. While the program is ideal for electricians, technicians and engineers who are new to PLCs, much of the content will be of value to those who already have some basic skills, but need a wider perspective for larger and more challenging tasks ahead. The accompanying material includes contributions from a number of experts and will become a valuable reference document in your work.

Practical Exercises

Various ladder logic programming exercises and simulations, including (but not necessarily limited to) the following:

- Sequential startup
- Multiple recipe sequences
- Multiple step sequence with common timers
- Split range valves
- Valve limit switch monitoring

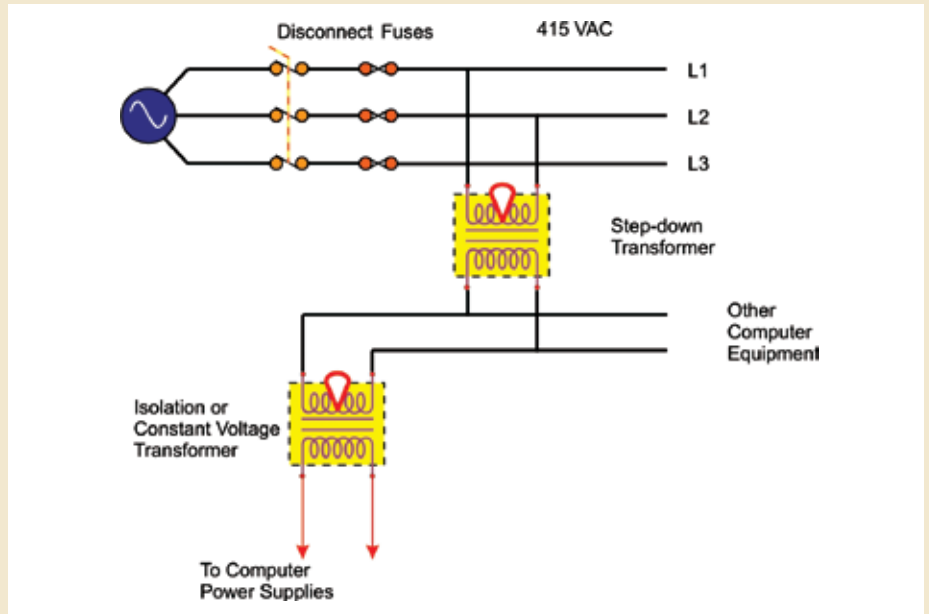
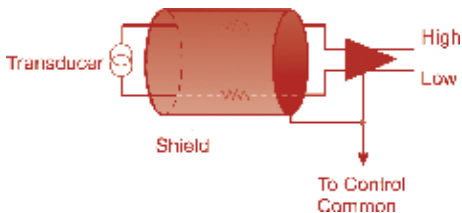

THE PROGRAM

Topic 17.1 - Introduction to the PLCs

- Processors, power supplies and programming devices
- Memory systems and I/O interaction
- Digital I/O systems
- Analog I/O systems
- Special function I/O and serial communication interfacing
- Good installation practices

Topic 17.2 - PLC Programming I

- Data acquisition
- Analog and digital control
- Fault tolerance
- Peripheral equipment
- Operator interfaces

Topic 17.3 - PLC Programming II

- High Security PLC systems
- Simulation and testing of systems
- Best documentation practice
- HMI (Human Machine Interface)

Topic 17.4 - Electrical Design and Construction

- Functional specification
- System configuration
- Installation and commissioning
- Working examples of PLC programs
- PLC applications in Mining

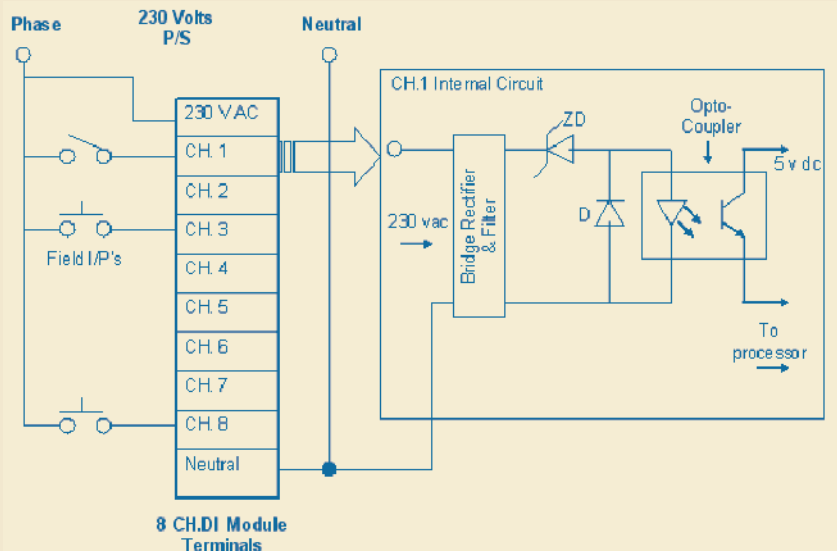

**You will learn how to:**

- Understand the concept of distributed control
- Identify the various components of a DCS system
- Identify processes that lend themselves to DCS automation
- Evaluate DCS offerings from the major vendors
- Design a basic DCS system

**Overview**

DCS (Distributed Control System) is a broad term for a type of system used in a variety of industries to monitor and control distributed equipment. DCSs are used in manufacturing systems, processes, or any kind of dynamic system in which the controller elements are not centrally located but are distributed throughout the system. Each component sub-system is controlled by one or more controllers. The entire system of controllers is connected by networks for communication and monitoring. DCSs are very similar to SCADA systems except for the fact that the data processing in a SCADA system is usually centralized, and SCADA performs high-level (supervisory) control only. DCSs are widely used in the mining industry.

**Practical Exercises**

- Case study: design a DCS for a given plant, using hardware from a selected vendor.

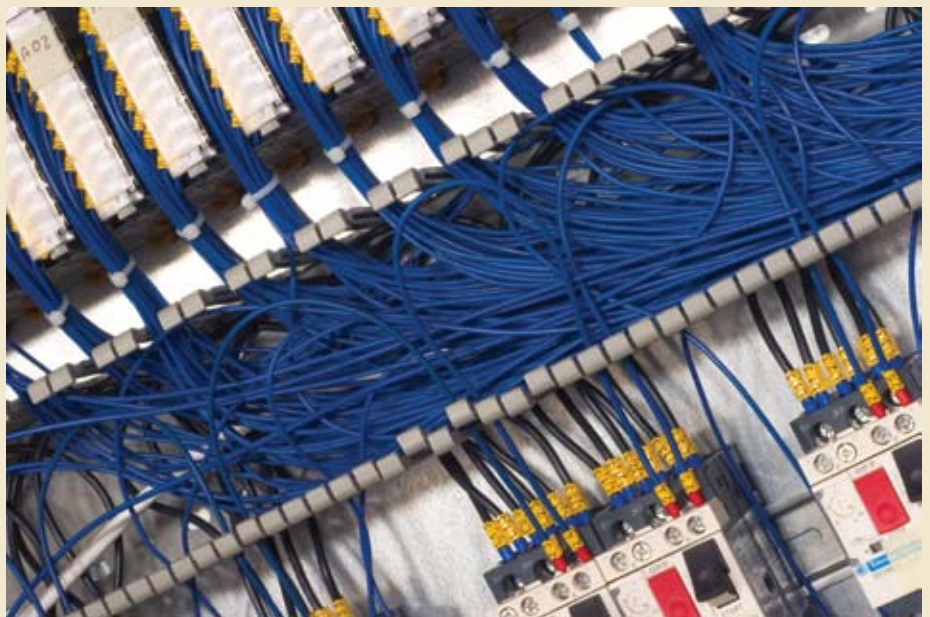

**THE PROGRAM**

**Topic 18.1 - DCS Basics**

- What is distributed control
- DCS vs. SCADA
- DCS system components
- Data communications for DCS
- The basic controller
- The operator interface

**Topic 18.2 - DCS Operation**

- Basic DCS controller configuration
- Programming of DCS systems
- DCS alarm system management
- DCS reporting
- DCS configuration
- Advanced control strategies maintenance
- DCSs for the mining industry

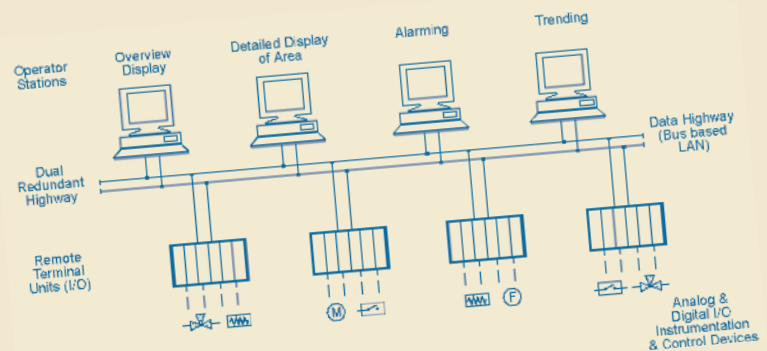
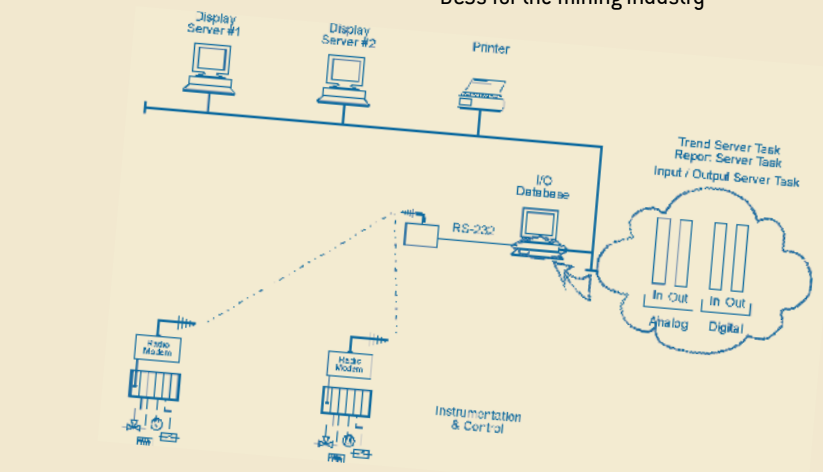
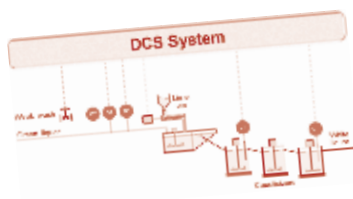

## You will learn how to:

- Become aware of state-of-the-art in analytical and management systems for the mining industry
- Identify the most appropriate system for your requirements

## Overview

The advent of expert systems and technologies such as GPS, WLANs, wireless mesh systems and RFID have enabled rapid strides in the development of systems that enhance safety and optimize mine productivity. Vehicles and individuals can now be tracked with pinpoint accuracy, while dangerous operations such as draglines and load-haul-dump can now be run without the presence of a human being. Expert systems can extract data from SCADA systems and make long-term mining optimization decisions. This module deals with current technology in this regard.

## Practical Exercises

Identification of commercially available systems in the following areas:

- Mining robotics
- Personnel tracking systems
- Vehicle tracking systems
- XRF analysis
- Specialized mining software (simulation, modeling etc)



## THE PROGRAM

### Topic 19.1 - Mining Robotics Applications

- Rock breaking
- Shovel loading automation
- Dragline automation
- Load haul dump automation
- Excavator guidance
- Blast hole charging

### Topic 19.2 - Personnel, Vehicle and Asset Tracking Systems

- UWB-based RFID tracking
- Wi-Fi-based RFID tracking
- GPS-based tracking
- DGPS (differential GPS)-based tracking
- On-board vehicle management systems
- Software suites for asset, vehicle and personnel tracking/management

### Topic 19.3 - Specialised Instruments, Devices & Systems

- Portable XRF analysers
- Conveyor belt XRF analysers
- Mine radar
- Electronic detonators
- Remote blasting systems
- Automatic pH monitoring systems

### Topic 19.4 - Specialised Software

- Expert systems
- Digital (3D) terrain imaging
- Drilling/blasting software
- Terrestrial communications modeling
- Haulage fleet analysis
- Dragline operations simulation
- Longwall face configuration and cutting cycle analysis



You will learn how to:

- Identify risk areas on both underground and open mines
- Identify current equipment and devices addressing those issues.

Overview

Safety systems in mines have come a long way since the caged canary and the Davy safety lamp. This module gives an overview of current safety systems and devices.

Practical Exercises

- Written assignment on commercially available mine safety devices and devices



THE PROGRAM

Topic 20.1 - Personal Safety

- Ultra-Low Frequency (ULF) pagers
- Integrated headlamps
- Proximity detection (collision avoidance) systems
- Gas detectors
- Slope stability monitoring systems
- Ventilation monitoring systems

